

FACTORY AUTOMATION

Programmable Automation Controllers MELSEC MX Controller





Mitsubishi Electric Corporation operates across a wide range of sectors, from home appliances and building systems to railway solutions, factory automation equipment, and satellites and leverages the synergy created by these diverse sectors to address various challenges and provide optimal solutions worldwide.

We, the Mitsubishi Electric Group, will continue to evolve in "carbon neutrality" and a "circular economy" by promoting innovation in products and services and providing integrated solutions through our business activities, all in order to realize a vibrant and sustainable society.

Under "Changes for the Better" which reflects the Mitsubishi Electric Group's commitment to "always strive to achieve something better", Mitsubishi Electric FA will expand the value of its products and services in the FA system business by advancing the provision and expansion of integrated solutions under the slogan "Automating the World" for an even better tomorrow. Through automation technology, we aim to contribute to innovation not only in the manufacturing industry but also across society as a whole.

We stand as your partner in shaping a smarter, more efficient, and more sustainable future.



The Mitsubishi Electric Group is actively solving social issues, such as decarbonization and labor shortages, by providing production sites with energy-saving equipment and solutions that utilize automation systems, thereby helping towards a sustainable society.

Lineup	5
Concept	8
Improving productivity	10
Sequence + Motion + Network	
Improving program development efficiency	20
One-tool engineering	
Reducing the machine management cost	28
Maintenance	
Digital transformation in factories	36
Security/information linkage	
Digital transformation	
Basic system configuration (MX-R model)	48
Basic system configuration (MX-F model)	50
List of CC-Link IE TSN connection devices	52
Specifications/Function list	54
Product list	58
Support	66

MELSEC MX Controller

MX = Manufacturing transformation



Series product lineup

Mitsubishi Electric programmable automation controller

MELSEC MX Controller

Mitsubishi Electric
micro programmable controller

MELSEC iQ-F
series



Mitsubishi Electric
programmable controller

MELSEC iQ-R
series



MELSEC MX Controller lineup

The MELSEC MX Controller integrates three types of control, sequence, motion, and network.

The MELSEC MX Controller has two models: MX-R model and MX-F model.

A diversified and sophisticated system can be constructed by using the MX-R models with the MELSEC iQ-R Series modules, and the MX-F models with the MELSEC iQ-F Series modules.

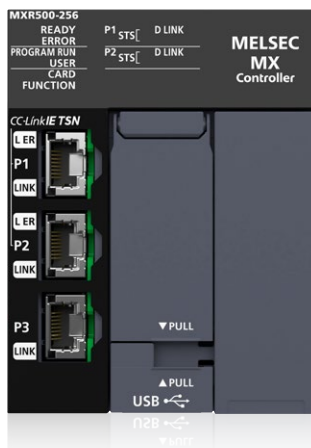

MX-R model*1

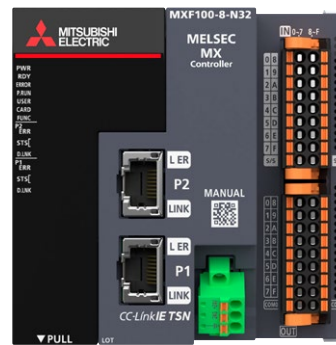

MX-F model

Model	Number of controllable axes (Real drive axes)
➤ MXR300-16	16 axes
➤ MXR300-32	32 axes
➤ MXR300-64	64 axes
➤ MXR500-128	128 axes
➤ MXR500-256	256 axes

Model	Number of controllable axes (Real drive axes)
➤ MXF100-8-□32*2	8 axes
➤ MXF100-16-□32*2	16 axes

*1: A base unit and power supply module of the MELSEC iQ-R Series are required. For details, refer to P.48.

*2: □ is either N: transistor output (sink) or P: transistor output (source). For details, refer to P.58.



One controller for all your control needs

Decades of expertise in programmable controller technology have been combined into a single controller.

By integrating sequence control, motion control, and network control on the MELSEC MX Controller platform, faster and more accurate control is achieved.

We will continue to add functionality to this platform, making it adaptable to a wide range of applications.

Equipped with a high-performance multi-core MPU as standard, enabling high-speed control

All functions of sequence, motion, and network are integrated. The motion control performance is **about 10 times**^{*1} higher than existing products of Mitsubishi Electric, achieving high-speed and high-accuracy motion control.

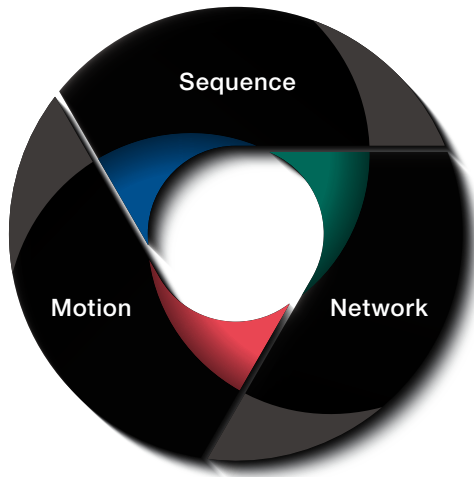

Compatible with multi-axis machines

Number of controllable axes (real drive axes)

MX-R	Maximum 256 axes
MX-F	Maximum 16 axes

Achieving high-speed motion performance

Motion control performance^{*3}

MX-R	Maximum 128 axes/1.2 [ms] ^{*3} Including program execution
MX-F	Maximum 16 axes/0.5 [ms]

Increased number of connectable stations

Number of devices connectable to CC-Link IE TSN

MX-R	Maximum 253 stations ^{*2}
MX-F	Maximum 46 stations

Greatly enhanced compute capability

Double-precision floating-point processing

MX-R	0.46 ns or faster
MX-F	2.50 ns or faster

LD instructions

MX-R	0.28 ns or faster
MX-F	1.25 ns or faster

*1: Comparison with the MELSEC iQ-R Series (64-axis control)

*2: Device stations supporting connections to 253 stations will be available in the future.

For details, refer to the Technical Bulletin (FA-A-0451).

*3: When the motion operation cycle setting is 1.5 ms



Improving productivity

Sequence + Motion + Network



Are you facing these challenges?

- Large system size with insufficient CPU performance
- Lack of synchronization accuracy at high speeds
- Need to customize equipment for specific applications



Achieve multi-axis machine control with one controller
P.10



Improving program development efficiency

One-tool engineering



Are you facing these challenges?

- Want to program in different languages to suit regional preferences or team members
- Large projects or equipment prone to bugs
- Long commissioning time due to equipment size



Reduce programming time and streamline development with one-tool engineering and intuitive operation
P.20



Reducing the machine management cost

Digital transformation in factories

Maintenance

Security/information linkage

Digital transformation



Are you facing these challenges?

Are you facing these challenges?

- Quickly recover from equipment failures
- Reduce equipment replacement costs

- Protect assets from cyberattacks
- Easily connect data between IT systems and devices
- Advance front-loaded design with simulations



Significantly reduce downtime with visibility into issues

P.28

Achieve centralized management and sharing of valuable data

P.36

Mitsubishi Electric's Digital Twin

P.42

Improving productivity

Sequence + Motion + Network

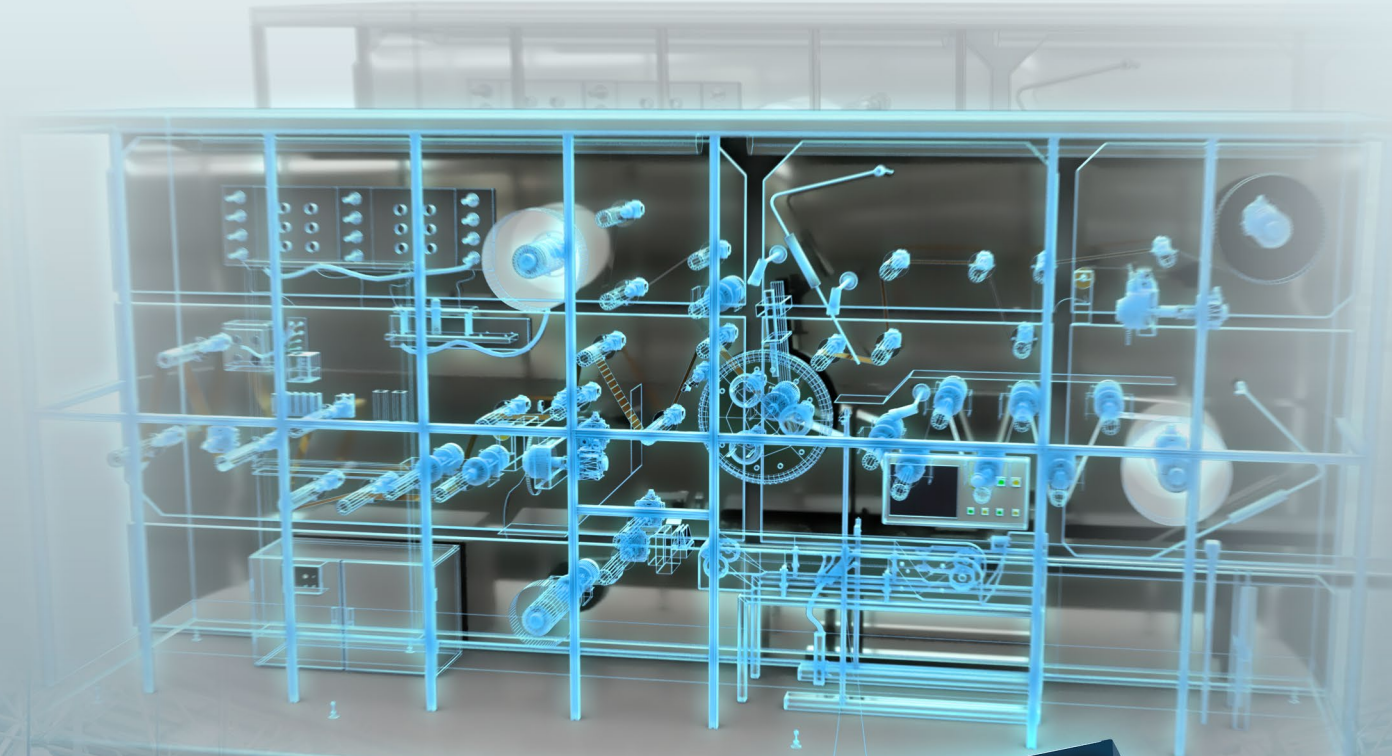

Achieve multi-axis machine control with one controller

The MX Controller, equipped with a high-performance multi-core MPU as standard, integrates sequence, motion, and network control, supporting up to 256 axes. It supports mixed operation cycles, ensuring high-speed control even with multiple axes. One controller delivers precise control of individual mechanisms and control of the entire production line.

Achieving high-speed and high-accuracy motion control

MX-R
MX-F

Multi-core MPU

A high-speed multi-core MPU significantly increases processing performance, including double-precision floating-point operations. Inter-core communication allows multiple cores to perform different tasks simultaneously, enabling parallel high-speed sequence, motion, and network control. Distributed control across cores shortens the overall production cycle.

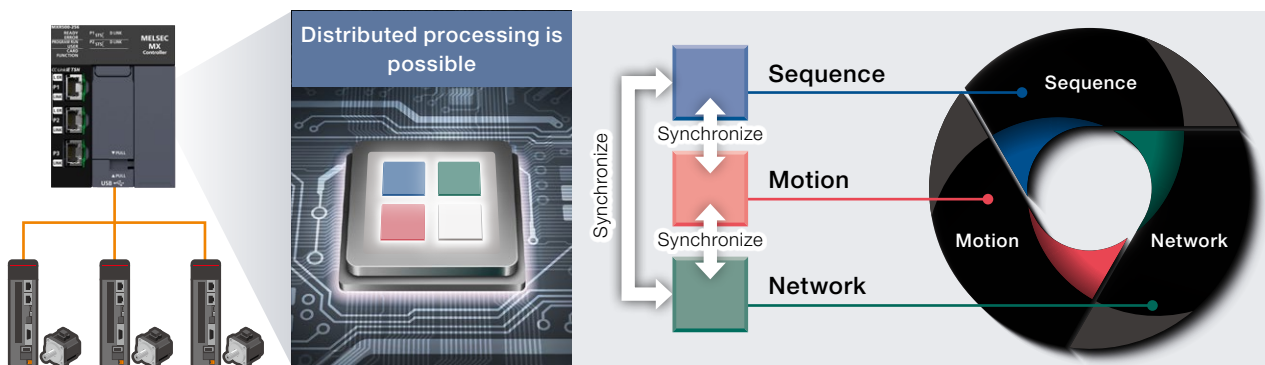

Core load can be monitored and adjusted for optimal machine control

The performance monitor visualizes the operation cycles and load status for each core assigned to run the program. Optimize performance by distributing load through mixed operation cycles based on visualized load status.

Program example

Item	Without load distribution	With load distribution
System configuration	One MXR500-□ + 98 axes of MR-J5	
Setting of the number of axes and operation cycle	98 axes (Operation cycle set to 250 μs)	High-speed axes: 4 axes (set to 250 μs) Low-speed axes: 94 axes (set to 4000 μs)

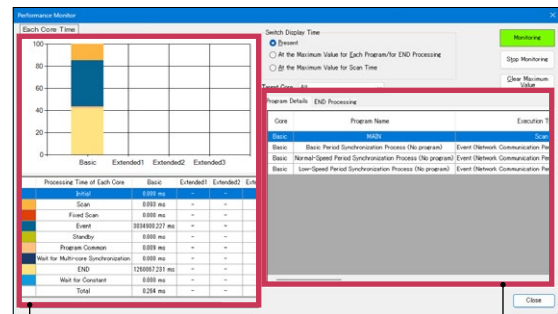

Graphical display of the breakdown of scan times and operation cycles¹ for each core, making even complex tasks easy to understand.

Detailed program information and END processing breakdowns for each core

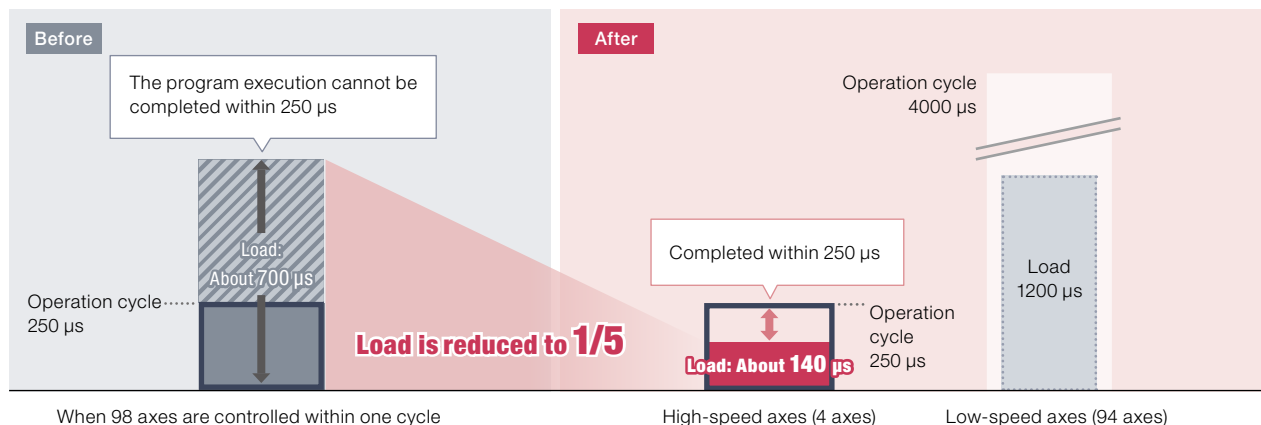

¹: Future support

Essential CC-Link IE TSN technology for large-scale equipment

MX-R

MX-F

High-speed and high-accuracy coordination with a wide range of devices

With a single MELSEC MX controller, you can build a system that combines real-time control communication for factory automation equipment with information communication for IT systems.

» What is TSN^{*1}?

TSN is a set of international standards, which define the time synchronization method and the time sharing method. By adding these to Ethernet technology, control communications (ensuring real time reaction), which cannot be performed with conventional Ethernet, and information communications (non-real-time communications) can be performed together.

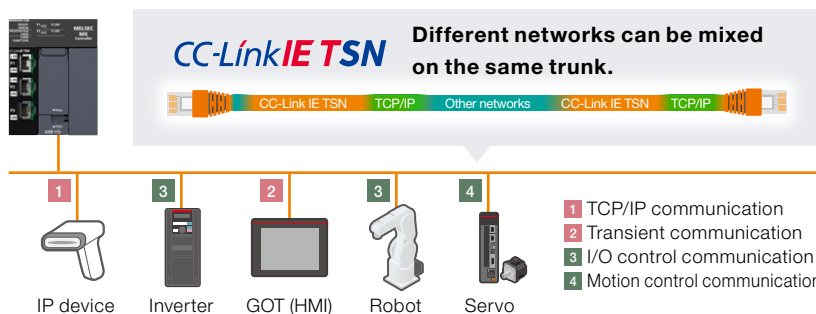

Symbol for TSN technology

The CC-Link IE TSN time sharing method enables communications independent of the number of device stations

The time sharing method used as the communications protocol allows simultaneous input and output communication between connected stations.

High-speed link scan significantly reduces production cycles. Mixed communication cycles are also possible, ensuring fast and smooth communication even with many device stations.

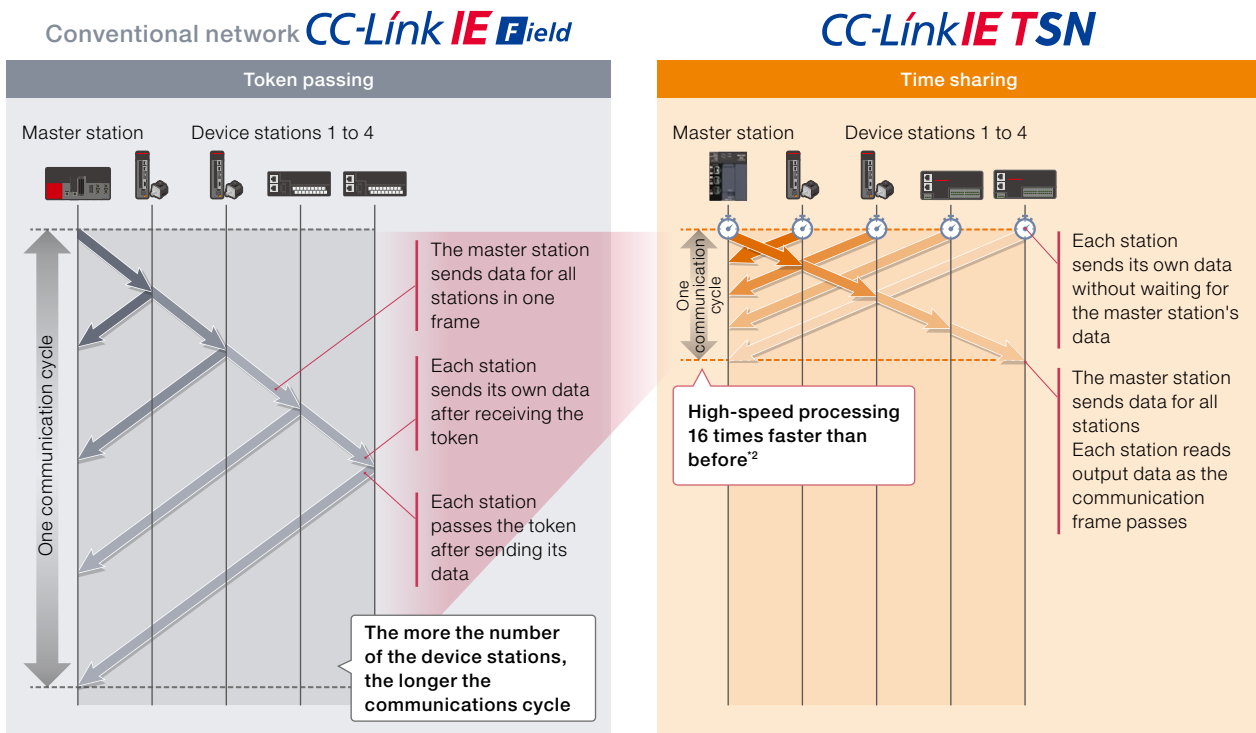

*1: Time-Sensitive Networking

*2: Under the same conditions

Optimizing control performance of entire system

MX-R

MX-F

With one MELSEC MX Controller, up to three different operation and communication cycles can be set for each axis and device station.^{*1}

There is no need for multiple CPU modules. This greatly improves the cost efficiency of your equipment.

Even for multi-axis machines, the control performance at high-speed operation cycles can be partially secured, improving accuracy in processes such as cutting.

Example: Winder



Three types of operation cycles can be mixed

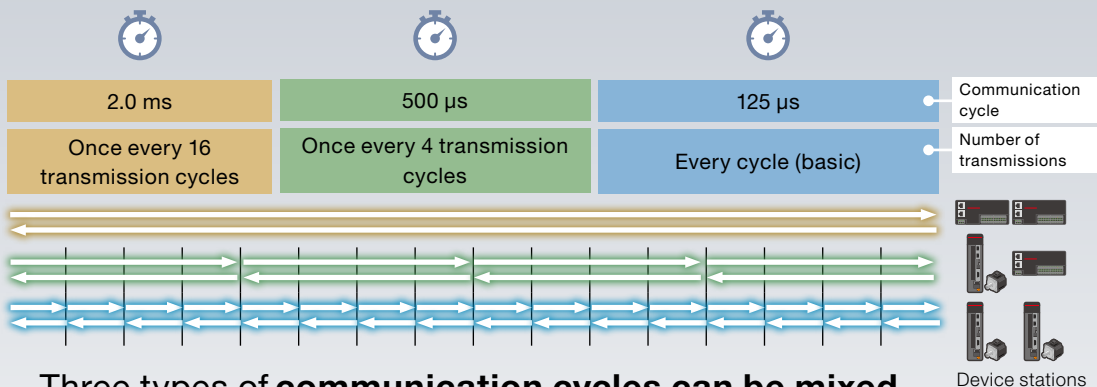
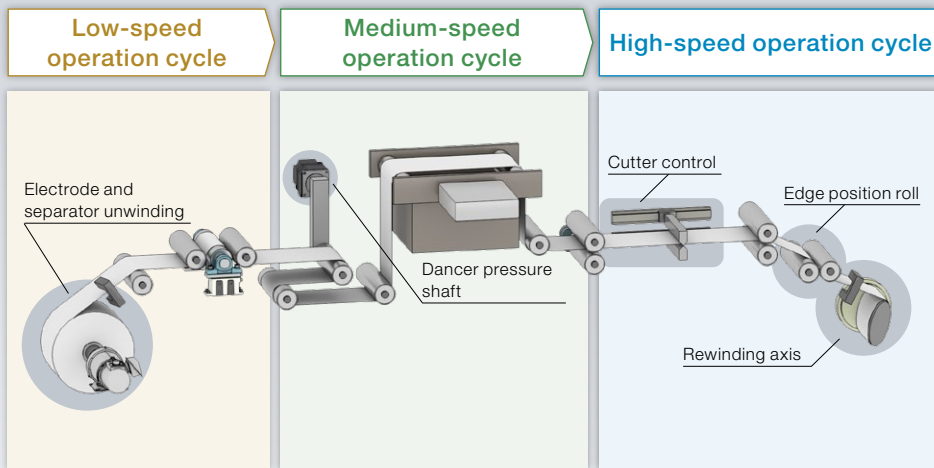

Three types of communication cycles can be mixed

CC-Link IETSN

*1: Using GX Works3, you can set communication cycles in the CC-Link IE TSN configuration setting window and operation cycles in the axis parameter settings.

Precise mark input and cutting not dependent on scan time

MX-R
MX-F

Even in applications that require high-speed I/O control without variability, such as roll-to-roll control, the MX Controller provides precise I/O over the network that is not dependent on the scan time. Minimized jitter in the I/O timing of mark detection and cutting reduces variations in web material detection and cut length. This improves yield in high-speed production lines.

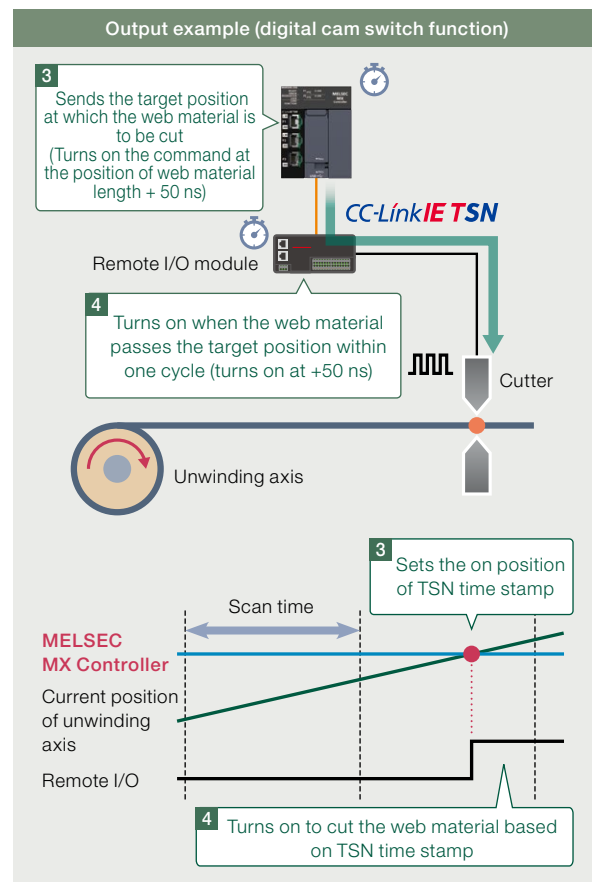
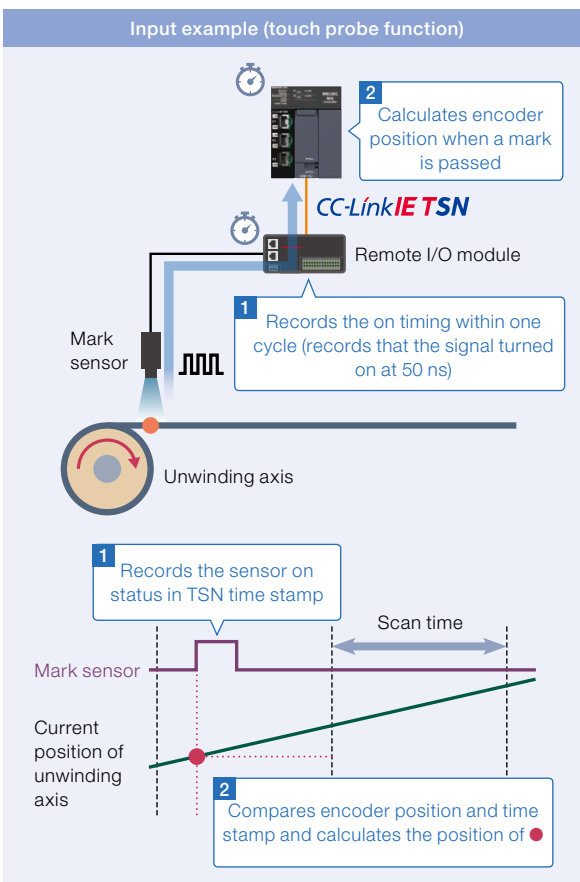
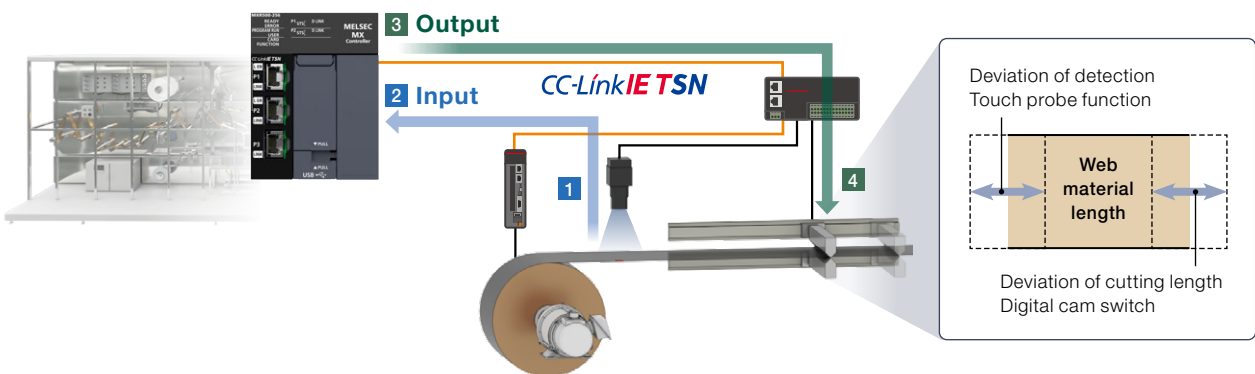

Control in the units recorded in the CC-Link IE TSN network time stamp (in units of ns) is possible.*1

*1: The actual I/O timing varies depending on the device used.

Intuitive operation with visual data

The digital cam switch settings can be configured using GX Works3.

Setting values by adjusting the graph on the screen with mouse operations eliminates the need to convert time, significantly reducing working hours.

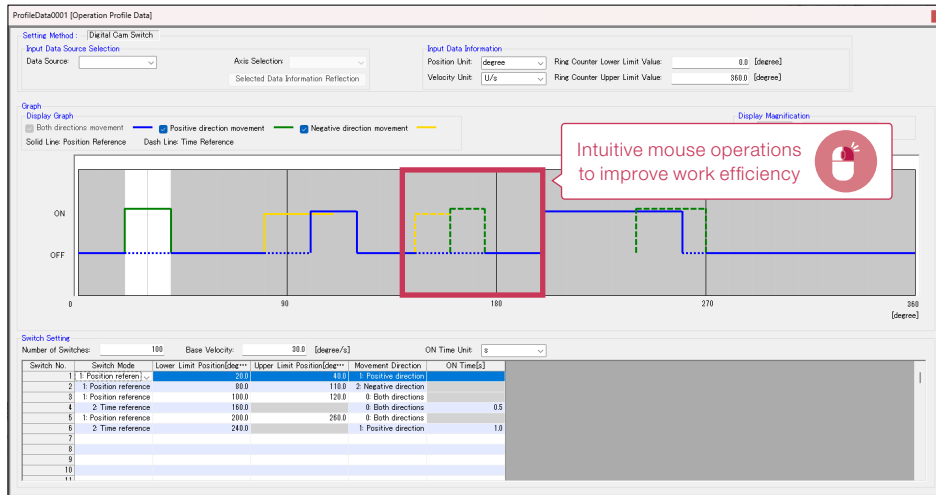

64-bit-compatible and highly accurate control

64-bit control minimizes rounding errors during calculations, ensuring highly accurate control.

Positioning range and resolution

Compared to 32-bit control, 64-bit control offers a broader positioning range while maintaining high resolution.

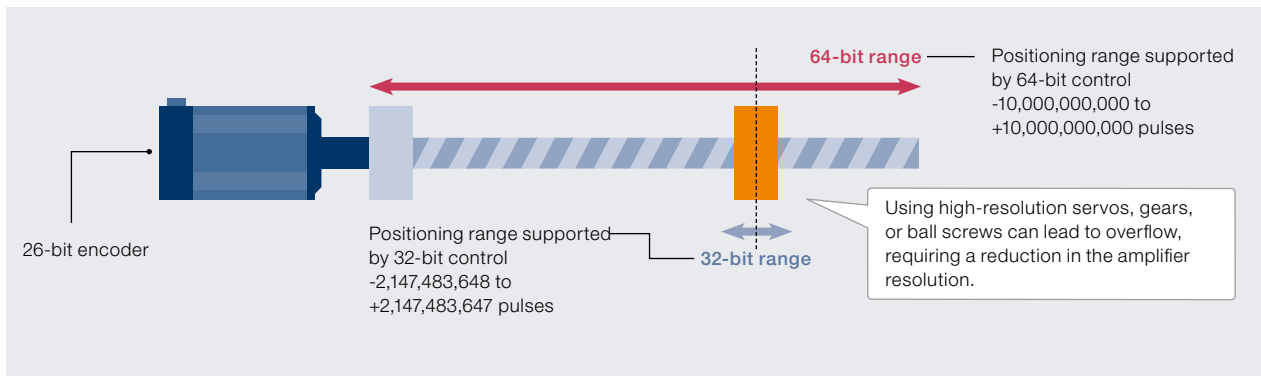

Absolute position control system and current position restoration

The MELSEC MX Controller performs 64-bit absolute position control, significantly reducing the risk of current position restoration error after power-off.

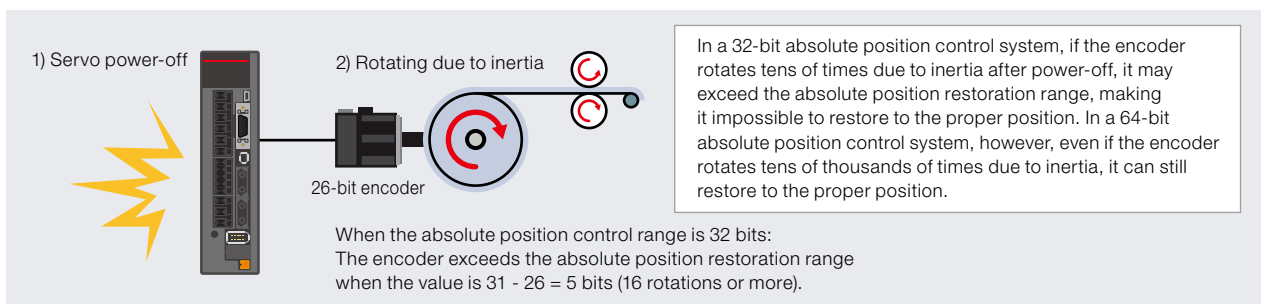

Optimize multi-axis system with graphical user interface

MX-R

MX-F

Advanced synchronous control*1

Software replaces machinery mechanisms (such as gears, shafts, speed change gears, and cams) for easier synchronous control. Even for machines that require multi-axis synchronization, such as winders and coaters, it is easy to adjust the cam control and operation pattern to eliminate position deviation. Fine-tuning the cutting position and adjusting the synchronization position according to the transportation speed can achieve high quality and high productivity.

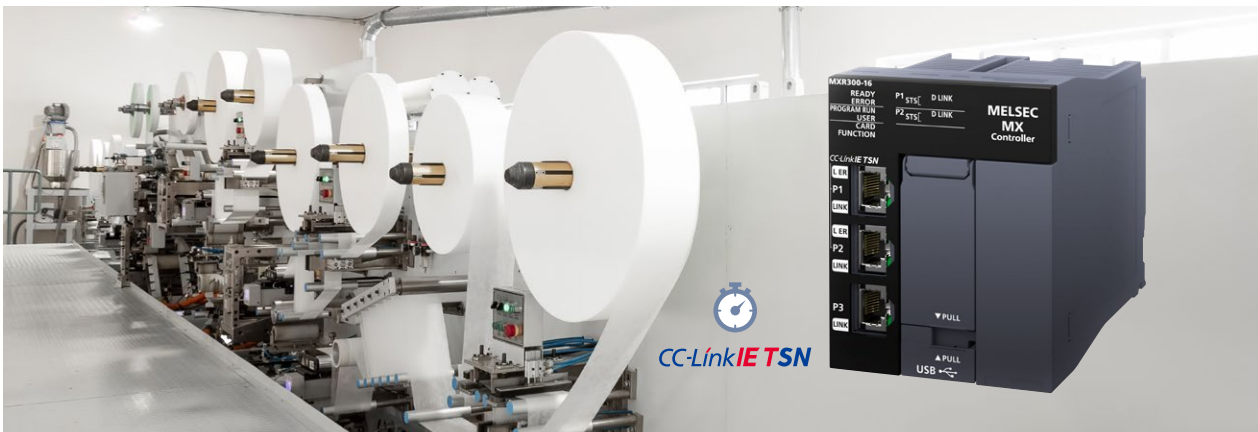

Synchronous control parameters

Item	Value
Axis Label/ID	1
Parameter Constant	AdvOutputPrConst
Output Axis Smoothing	0 ms
Main Shaft Clutch Smoos	0 ms
Auxiliary Shaft Clutch	0 ms
Main Shaft Speed Chain	0 ms
Auxiliary Shaft Speed C	0 ms
Output Axis Speed Cha	0 ms
Parameter	AdvOutputPrExp
Sub Input Axis Object	
Auxiliary Shaft Object	
Gear Parameter	
Composite Main Sha	0001>Main Shaft In
Main Shaft Gear: Nur	1
Main Shaft Gear: Der	1
Composite Auxiliary	0001>Main Shaft In
Auxiliary Shaft Gear: 1	
Auxiliary Shaft Gear: 1	
Main Shaft Clutch ON	0
Signal	
Target	
Signal Detection Met	0:Detection at TR
Compensation Time	0.0 s
Filter Time	0.0 s
Main Shaft Clutch OFF	
Signal	

The intuitive visual interface makes it easy to create cam data and configure parameters. This enables low-code development of complex multi-axis synchronization programs, significantly increasing work efficiency.

Cam data (operation profile data) setting window



*1: Motion control FBs are used.

Achieve high-speed, high-response, and stable pressure control

MX-R
Future support
MX-F

The analog signal from a pressure sensor (load cell*) is input to the MR-J5-G-LL to control the pressure. The pressure can be kept constant even while the load is changing. High-response pressure control is possible by applying a pressure model to reduce over-pressing.

Example of pressure control

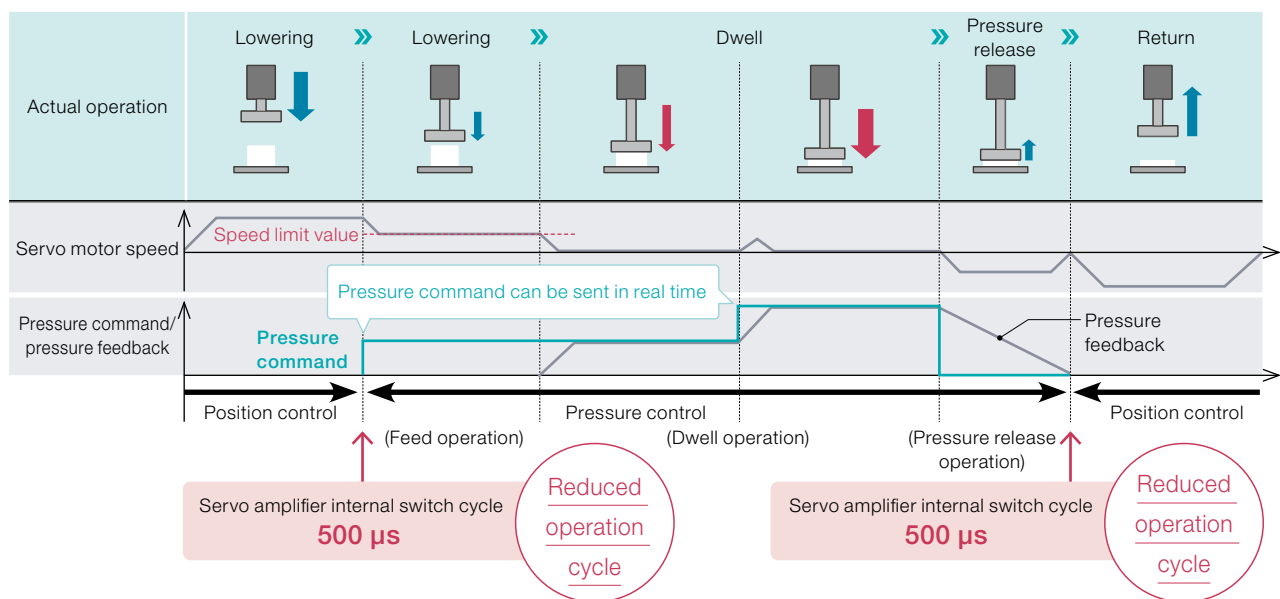

Supporting applications with high real-time reaction

By combining the MX Controller with the MR-J5-G-LL, which supports cyclic pressure control mode (csp), the servo amplifier performs feedback control of pressure according to the pressure command of the function block. The pressure control loop operates independently of the controller, achieving high-speed and high-response control.

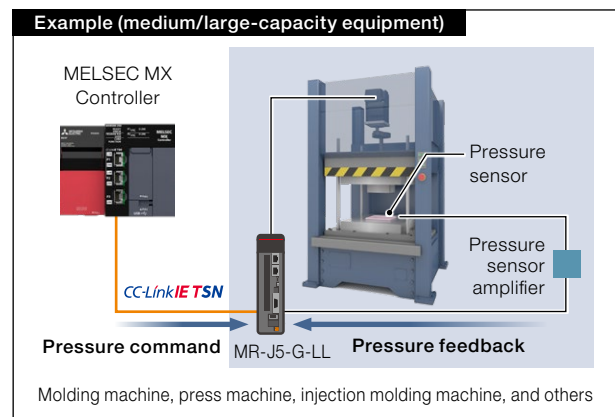
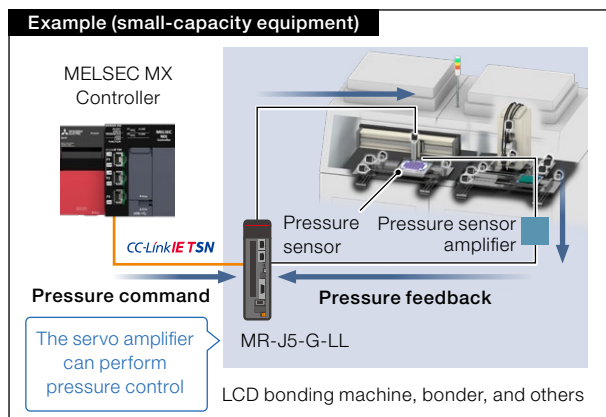

High-accuracy and stable pressure control can be achieved.

*1: A force sensor that enables force measurement by converting force into an electrical signal

Develop more advanced control loops

MX-R
MX-F

Motion cyclic control

- The MX Controller supports motion cyclic control, allowing the transmission of target torque, position, and speed with each operation cycle, in addition to standard positioning operation.
- Setting the task type to "network communication cycle synchronization" ensures deterministic performance from programmable controller tasks to network transmission.
- The floating-point operation performance is improved by about 15 times^{*1}.



These allow program execution, motion operation, and network send/receive to be performed within the same communication cycle. This makes it possible to implement advanced control loops that generate control commands from the user program in real time and instantly transmits sensor values to drives.

Before Conventional position control

Only positioning in predefined operation patterns can be performed.

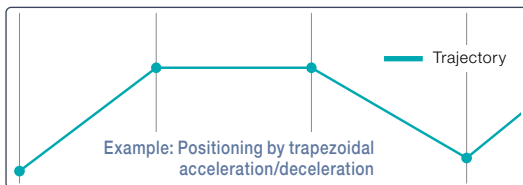

After Motion cyclic control

Servos can be controlled by feed back control programs linked to external sensors.

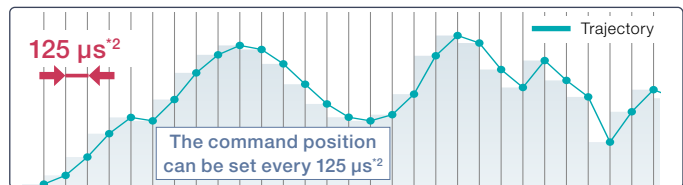

Example



Application example



Position control

Robot (coordinate transformation), camera stage correction, and others

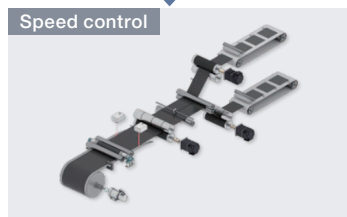

Speed control

Tension feed back and others



Torque control

Feed back control by pressure or external encoder and others

» Advanced applications can be achieved

- High-speed real-time feed back control
- Deterministic data transfer is ensured from program execution to data transfer to the servo.
- Computational operation using the floating-point can be easily performed.

Achieve real time control

Punctuality from input to data transmission over the network is assured using network communication cycle synchronization tasks.

*1: Comparison with the MELSEC iQ-R Series
*2: The maximum operation cycle for an MX-F model is 250 μs.

Variety of devices available through our partnerships with leading manufacturers

MX-R
MX-F

Drive motors from partner manufacturers with MELSERVO-J5

By using MELSERVO-J5, you can standardize your servo amplifiers and reduce the number of spare parts needed. Through cooperation with various partner manufacturers, suitable products can be chosen from various types of motors.^{*1}

Partner motors

Driven by
MELSERVO-J5

Akribis
where precision matters

Akribis Systems Pte Ltd

DGL/AXD Series

WITTENSTEIN
WITTENSTEIN Ltd.

axenia value Series

FUJI Linear

FUJI Linear

SLM Series

IKO

NIPPON THOMPSON CO.,LTD.

NT...V/SA...DE Series

MTL

Microtech Laboratory Co., Ltd.

µDD Series

THK

THK America, Inc.

GLM/CCR Series

Combination with drive units from other manufacturers

The MELSEC MX Controller can work not only with MELSERVO but also with drive units from other manufacturers that support CC-Link IE TSN.

Partner drives

FASTECH
Fast Accurate Smooth Motion

FASTECH Co., Ltd.

Ezi-SERVO Lineup

NPM
Nippon Pulse Motor Co., Ltd.

CLET-AD Series

IAI
Quality and Innovation

IAI CORPORATION.

RCON system

CC-Link IE TSN

Partner devices

NSD Corporation

NSD Corporation

Encoder

Setting image

*1: For details on individual motor drives, please consult your local Mitsubishi Electric representative.

Improving program development efficiency
One-tool engineering

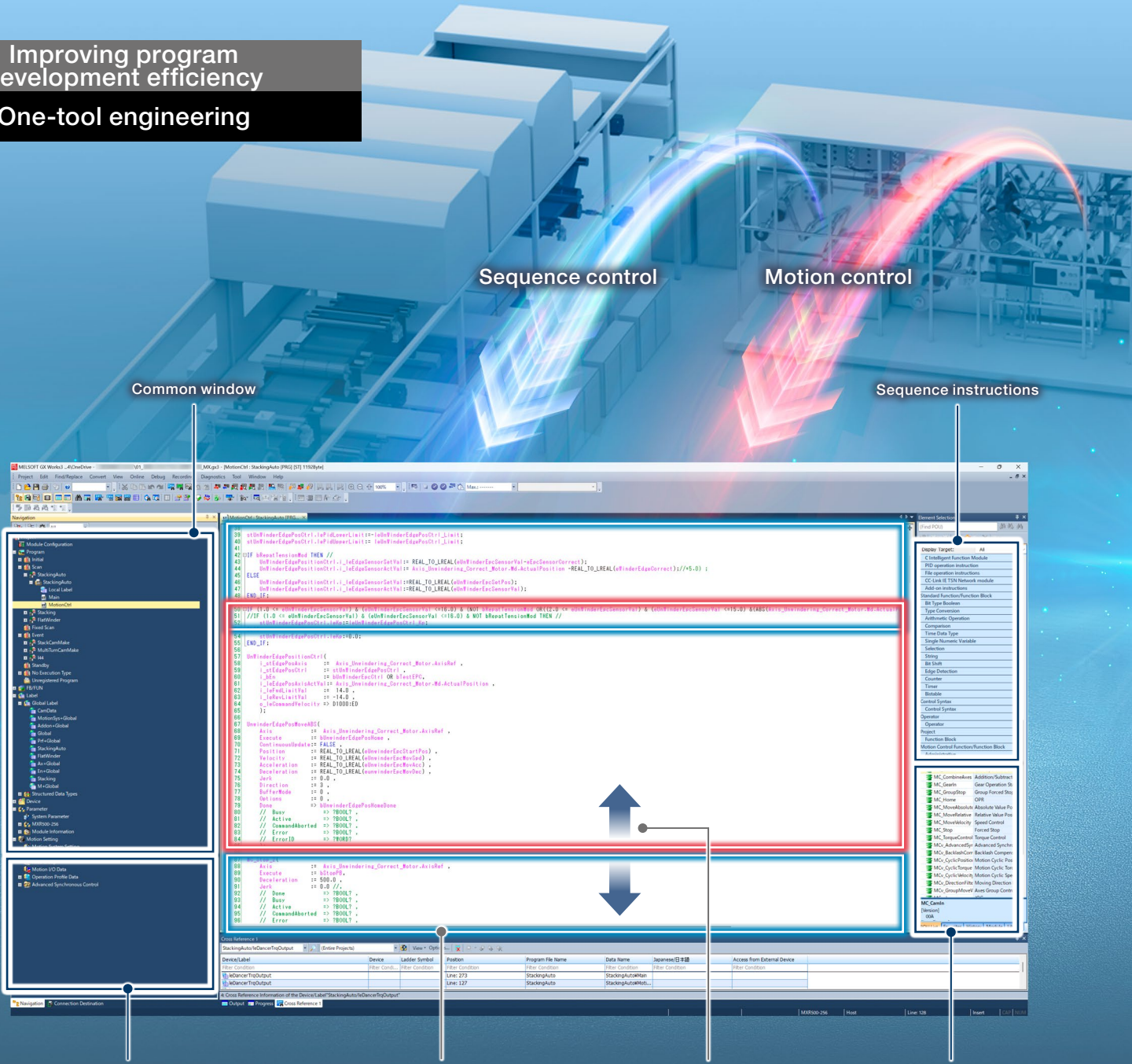

Motion setting window

Sequence program and motion program can be mixed

No refresh between sequence program and motion program

Motion instructions

Reduce programming time and streamline development with one-tool engineering and intuitive operation

Sequence control and motion control programs are combined into one. There is no need to create separate programs for each module or exchange data, simplifying your programs. With a single tool handling both sequence and motion control programs, you can easily modularize the program into components, manage change history, and debug.

Programming using IEC 61131-3 languages

MX-R
MX-F

Ladder diagram (LD), structured text (ST), and function block diagram (FBD) are supported. Motion control programming also supports LD, ST, and FBD, allowing the use of FBs that conform to the international PLCopen® Motion Control FB standard.



Function block diagram (FBD)

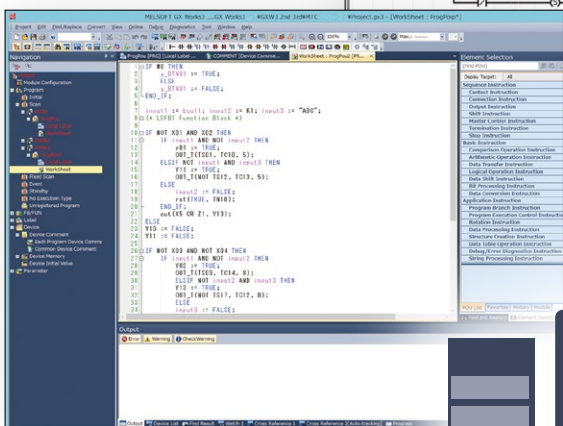
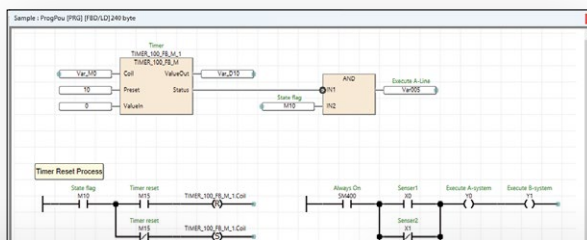

Structured text (ST)

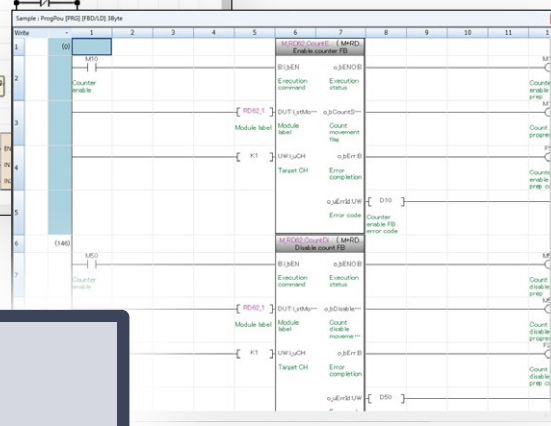

Ladder diagram (LD)

GX Works3



The PLCopen®-compliant Motion Control FB interface is standardized, making it easier for others than the original programmer to understand program content, reducing design and maintenance time.

Reduce programming effort with labels and structures

Improve program readability by managing signals such as sensor signals with labels named according to their role and use. Using labels allows you to program without worrying about devices used in other programs when creating multiple programs.

» What is a label?

A variable that is used by a program, instead of a device. Label names and data types can be defined optionally according to their role and use. Program readability can be improved by using labels.

	Label Name	Data Type
1	bTransfer	Bit
2	sSensorData	String(32)
3	Start_switch	Bit
4	Stop_switch	Bit
5	In_operation	Bit

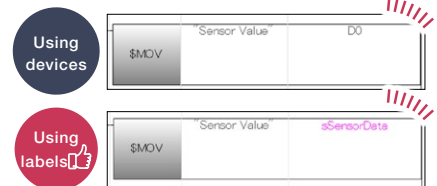

- Duplication of addresses used by devices does not need to be considered.
- The usage of data can be understood from the specified label name even without a comment.
- Changes to a label are reflected in all the same labels, so that working hours can be reduced.

» What is a structure?

A structure unifies labels of multiple types (data types) to define a new data type. Using structures helps arrange and manage data and improves reusability.

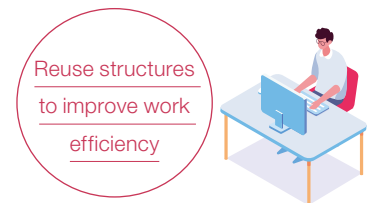

• Defining data with only labels

	Label Name	Data Type
1	sensorA.sLabel1	String(32)
2	sensorA.bLabel2	Bit
3	sensorA.wLabel3	Word [Signed]
4	sensorA.wLabel4	Word [Signed]
5	sensorB.sLabel1	String(32)
6	sensorB.bLabel2	Bit
7	sensorB.wLabel3	Word [Signed]
8	sensorB.wLabel4	Word [Signed]

It is difficult to reuse data sets because they are defined in connection devices without being compiled

• Defining members (data) of a structure

	Label Name	Data Type
1	sLabel1	String(32)
2	bLabel2	Bit
3	wLabel3	Word [Signed]
4	wLabel4	Word [Signed]

• Defining the created structure in labels

	Label Name	Data Type
1	sensorA	Sensor_Status
2	sensorB	Sensor_Status

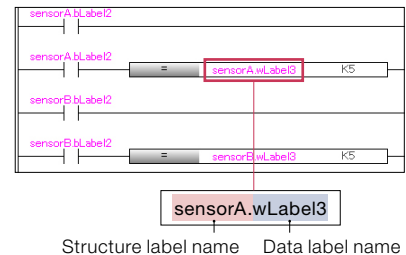

- Data structures can be reused among programs that perform similar processing.
- Structures can also be reused in programs of other machines.

» What is an array?

Data of the same type can be managed by number in an array. You can easily handle large amounts of data by using arrays.

Multiple devices can be used as arrays or structures

The label information (network labels) of devices can be used as bit arrays, structures, and structure arrays, so that programming efficiency can be improved.

1 The label information of a device can be generated as a structure.

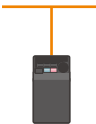

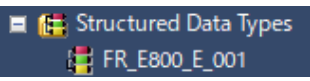

2 The bit string within a device can be generated as an array.

Order	Allocated link device
[0]	RX0
[1]	RX1
[2]	RX2
[3]	RX3
[4]	RX4
⋮	⋮
[15]	RXF

3 Multiple devices can be generated as a structure array.

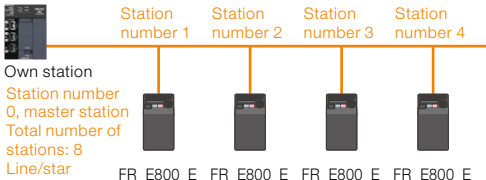

Own station
Station number 0, master station
Total number of stations: 8
Line/star

Index number	Allocated device
[0]	FR_E800_E_001
[1]	FR_E800_E_003
[2]	FR_E800_E_004
[3]	FR_E800_E_002

■ Programming, such as index specification, can be performed by specifying an array element in the structure array.

Supporting arrays

By defining elementary data types, structures, and FB types as an array, the same FB can be declared/described at once. The program can be simplified because there is no need to call the same FB again.

Before

	Label Name	Data Type
1	Recipe1	MC_MoveAbsolute
2	Recipe2	MC_MoveAbsolute
3	Recipe3	MC_MoveAbsolute
4	Recipe4	MC_MoveAbsolute
5	Recipe5	MC_MoveAbsolute

Each FB declaration requires one row of data

```

1 Recipe1 (Execute := TRUE) ;
2 Recipe2 (Execute := TRUE) ;
3 Recipe3 (Execute := TRUE) ;
4 Recipe4 (Execute := TRUE) ;
5 Recipe5 (Execute := TRUE) ;
                    
```

Call processing is complicated
(Program readability decreases/memory usage increases)

MELSEC MX Controller

	Label Name	Data Type
1	Recipes	MC_MoveAbsolute(1..5)

```

1 FOR RecipeNo := 1 TO 5 BY 1 DO
2   Recipes[RecipeNo] (Execute := TRUE) ;
3 END FOR;
                    
```

Simple FB declaration/
program

■ The same FB can be declared/described at once so that programming time can be reduced.

Supporting the label initial value setting in a table format

You can set initial values for array elements and structure instances on the label editor. This eliminates the need for initial value setting programs, reducing the program capacity and the scan time.

	wLabel1[0]	wLabel1[1]	wLabel1[2]	wLabel1[3]
	Word [Signed]	Word [Signed]	Word [Signed]	Word [Signed]
[0]	10	11	12	13
[1]	20	21	22	23
[2]				
[3]				
[4]				

You can create label initial values using Microsoft® Excel® and easily copy and paste them

■ The initial values can be set to array elements, reducing the programming time.

Streamline your project development by modularizing programs into components

Increase program reusability by using label names, FBs, structures, and arrays to modularize a program into components. This approach not only reduces development time but also creates more readable programs. It also ensures consistent programming quality regardless of developer skill level. Each component can be assigned to a specific member, clarifying roles and responsibilities.

Example of combination of labels, FBs, and structures

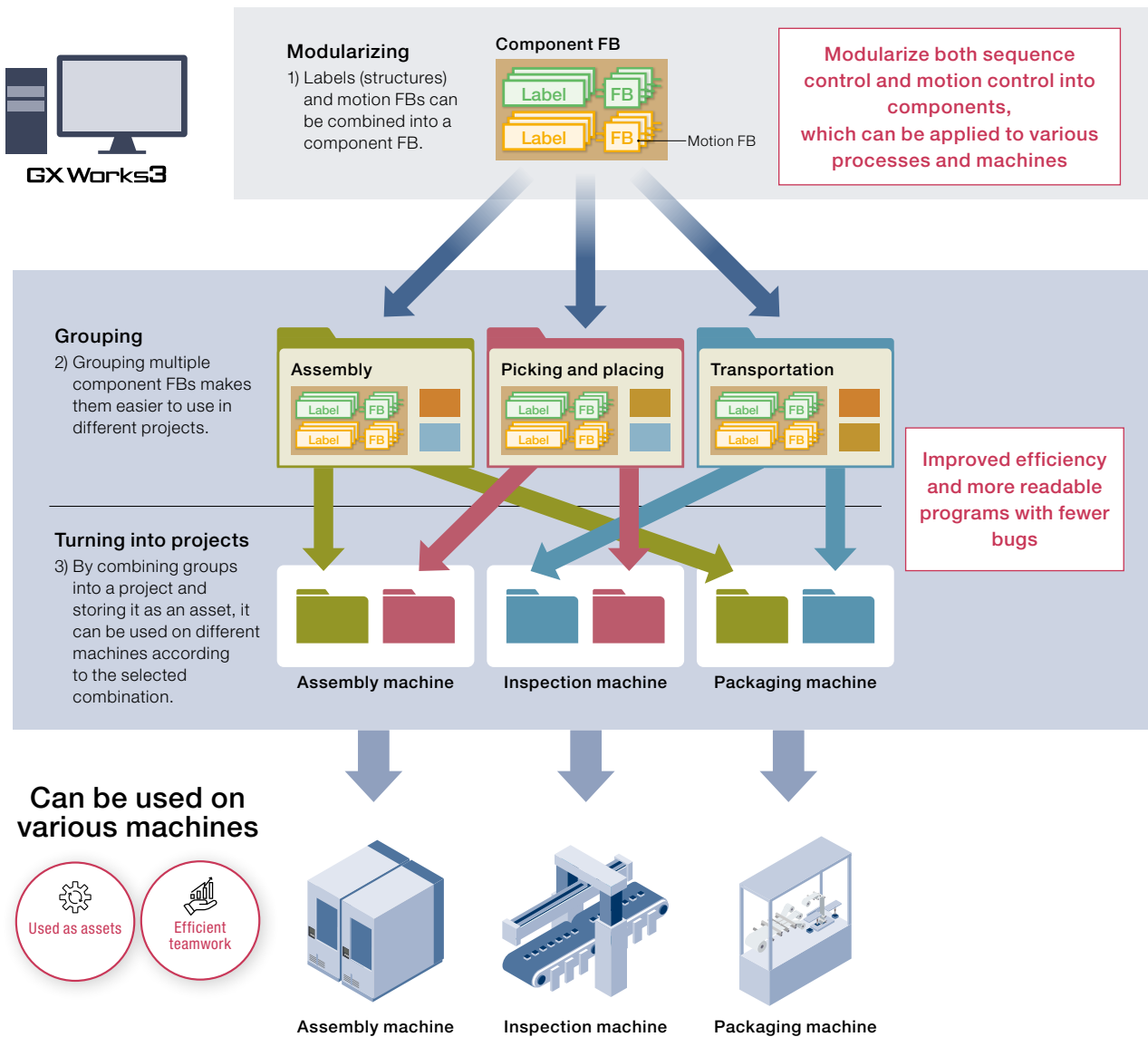

Efficiently develop large-scale projects with multiple members using program configuration management

MX-R
MX-F

Program configuration management enables program reuse and collaboration. Changes made by others are reflected immediately, with centralized history management for easy tracking of changes.

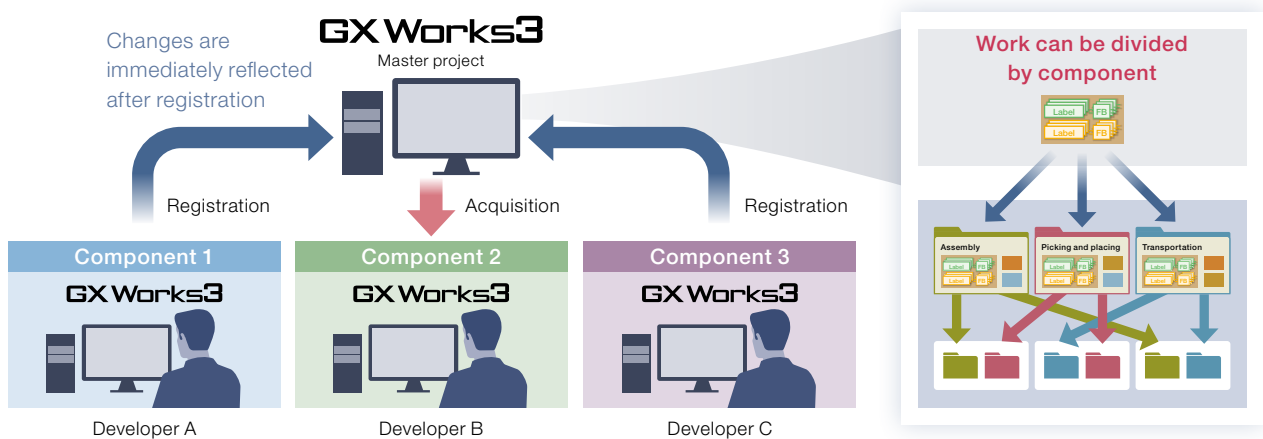

Program history log can be kept

You can track which version caused a machine failure.

Data can be restored for only a specific part

Sudden machine failures can be responded to quickly.

• Data registration method

Register a program of component 1 to the master project

• Verification method

Verify data

Latest data is added to the history list

• Rollback method

Acquire the past data

- You can track who changed which components and when.
- Edited data is not overwritten by others.

The project can be restored to a state before a failure occurred.

Reduce commissioning time for multi-axis machines

Easy axis generation

Real drive axes can be generated from network configuration information. Generating axes based on network configuration settings reduces the time and effort required to set up axes.

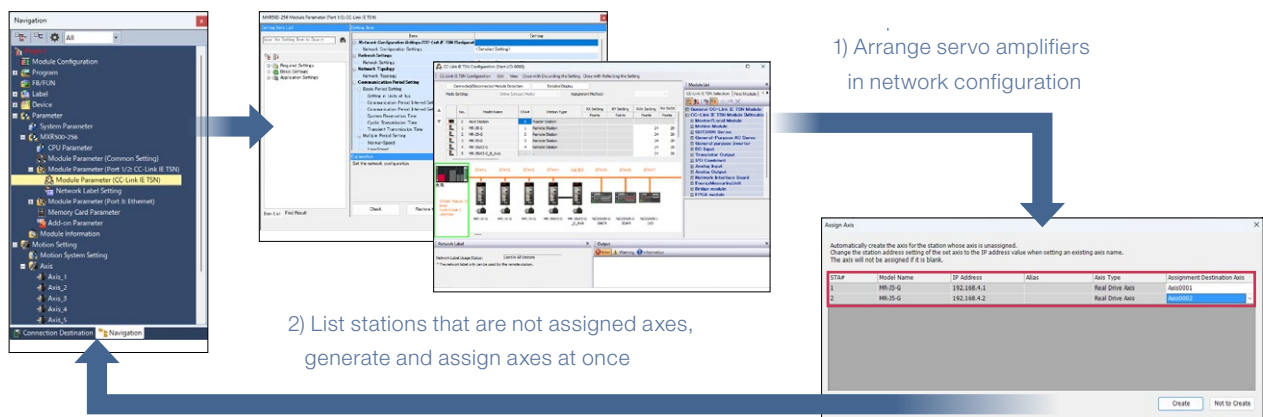

■ Axes can be generated at once for servo amplifiers that are not assigned axes.

Setting IP addresses of axes at once

You can view a list of stations assigned to each axis and change their IP addresses.

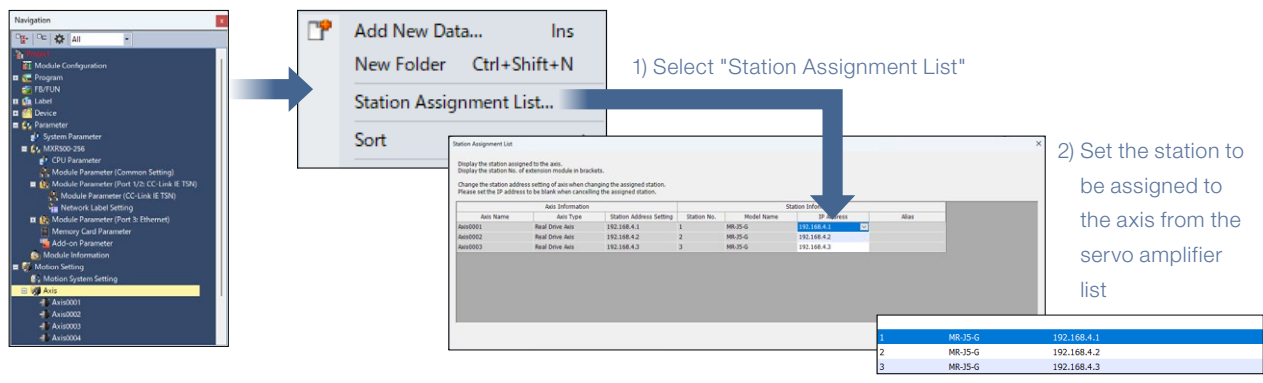

■ The IP address of the station to be assigned to the axis can be set at once.

Easy multi-axis positioning settings

You can set multi-axis positioning data (point table) from a dedicated window. Continuous positioning can be performed with one FB.

The screenshot shows a window titled 'Axes Group Selection' with a dropdown menu set to 'AxesGroup001'. Below is a table with columns: No., Operation Path, Control Method, Interpolation Axes, Circular Interpo..., Path Selection, Target Position..., Direction Selec..., Border Point/C..., Velocity Mode, and Velocity. The table contains six rows of data, each representing a different positioning point with various parameters like target position and velocity.

Callouts from the image:

- Set parameters such as velocity**: Points to the 'Velocity' column in the first row.
- Multi-axis positioning data operation FB**: Points to the 'MCv_MovePositioningData' block in the IEC Ladder Logic diagram.
- Start and end instructions are performed by one FB**: Points to the 'Positioning Co...' row in the table.

The IEC Ladder Logic diagram shows the following connections:

- MCv_MovePositioningData** (Function Block) is connected to:
 - DUT:AxesGroup** (Data Object) -> **AxesGroup:DUT**
 - DUT:PositioningData** (Data Object) -> **PositioningData:DUT**
 - B:Execute** (Boolean) -> **Done:B**
 - UW:StartDataNo** (Word) -> **Busy:B**
 - ENUM:BufferMode** (Enum) -> **Active:B**
 - UD:Options** (Data Object) -> **CommandAborted:B**
 - UD:Options** (Data Object) -> **ErrorID:UW**
 - UD:Options** (Data Object) -> **CurrentDataNo:UW**
 - UD:Options** (Data Object) -> **PrereadingDataNo:UW**
 - UD:Options** (Data Object) -> **RemainingLoopCount:UW**

- The FB with multi-axis control is supported.
- FB control data can be set collectively on the dedicated window.
- By creating multiple operating patterns, continuous positional control can be implemented with one FB.

Reducing the machine
management cost

Maintenance



Significantly reduce downtime with visibility into issues

Achieve speedy root cause analysis through system-wide recording of operational status
and extraction of anomalies using AI.

Record system-wide data over the network

Future support

MX-R

Future support

MX-F

Workpiece status and operation history are fully recorded along with control data from each equipment and machine before and after a problem occurs. View time-synchronized recorded waveform data, programs and video to easily identify the root cause. This allows you to quickly and comprehensively investigate the cause and prevent problems from recurring.

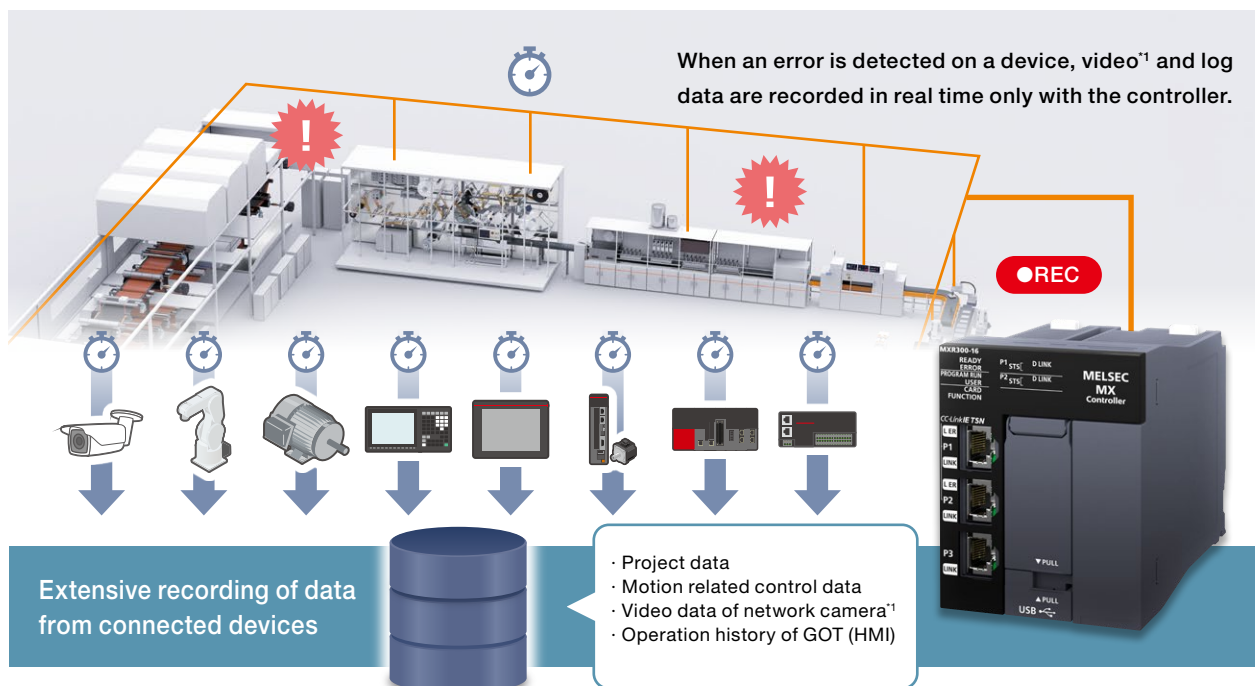

Data is automatically recorded before and after a problem occurs and at the start of the facility cycle

» Recording before and after a problem occurs

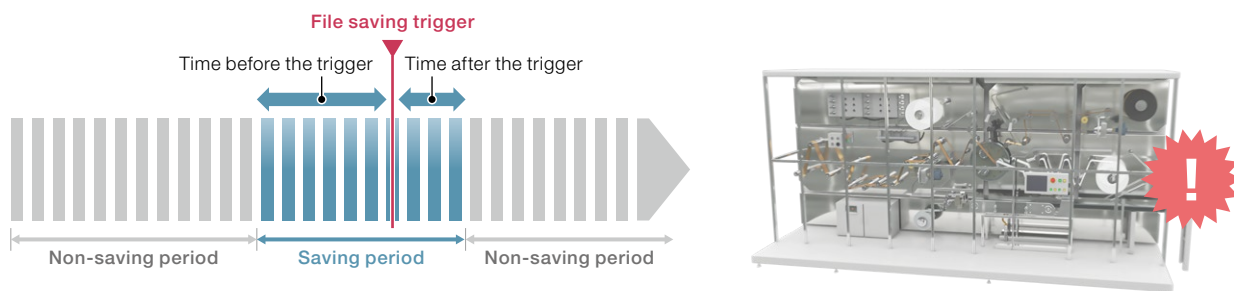

■ Data is recorded for specified periods before and after a problem occurs, enabling efficient root cause analysis

*1: A camera recorder module is required.

Easily review items that need attention by marking problem areas

Future support
MX-R

The vast amount of recorded data is narrowed down to the items that need attention, reducing the time and effort required to identify the root cause.

- GX VideoViewer Pro
- GX VideoViewer
- GX LogViewer
- GX Works3

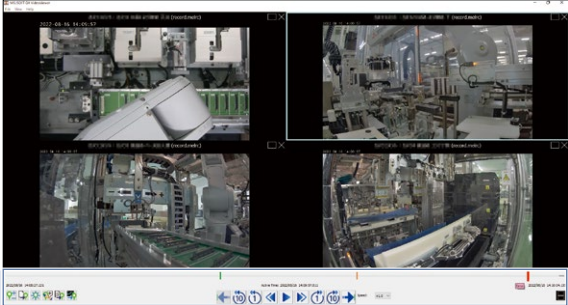

- Record points in the video
- Categorize and record points in the video
- Compare and analyze multiple videos and data



Color-coding of log marker by type

Frame-by-frame playback with different speeds

Comment display with mouseover

AI analysis instantly extracts differences in appearance and movement

Future support
MX-R

GX VideoViewer Pro uses AI to automatically detect anomalies in video and adds log markers at points of deviation from normal conditions. This streamlines the process of pinpointing the cause of problems.

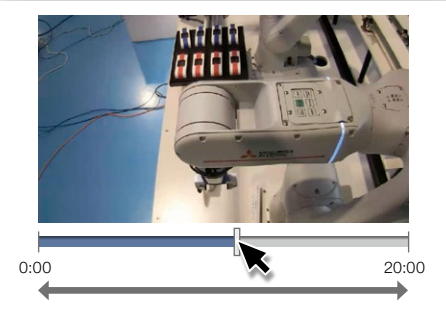

0:00 20:00

Visually check the difference

GX VideoViewer Pro

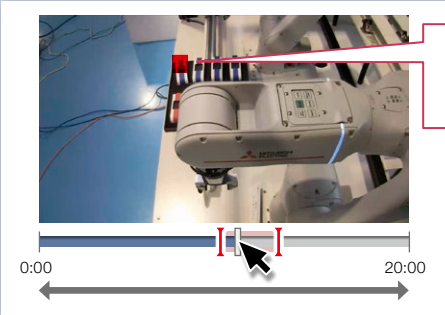

0:00 20:00

Marking a difference automatically

■

 Difference on the video

⎓

 Difference on the seek bar

AI assists in extracting the difference

- Human visual inspection can miss anomalies.
- The time required depends on the skill of the worker.

- Anomalies are extracted and marked on the video and seek bar, making review easy.
- Anomalies can be detected even in high-speed motion that the human eye cannot follow.

Root cause analysis made easy with coordination between tools

Future support
MX-R
Future support
MX-F

Even if the playback speed is changed, the timing between the video, program monitor, and device waveform data can be maintained, each showing the target moment. You can analyze from multiple perspectives while checking points of change.

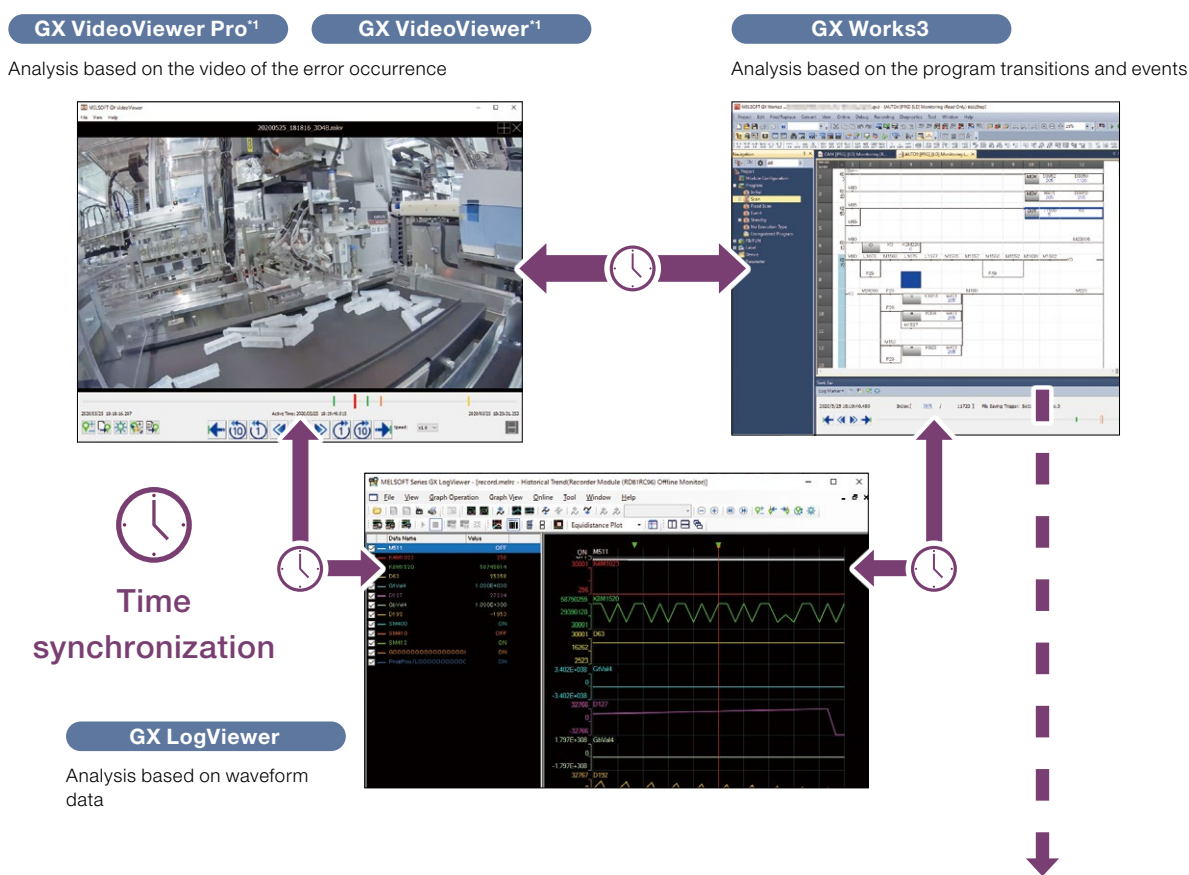

Check the range affected by a device/label at a glance

You can check the range affected by a device/label at a glance, making it easy to perform integrated analysis.

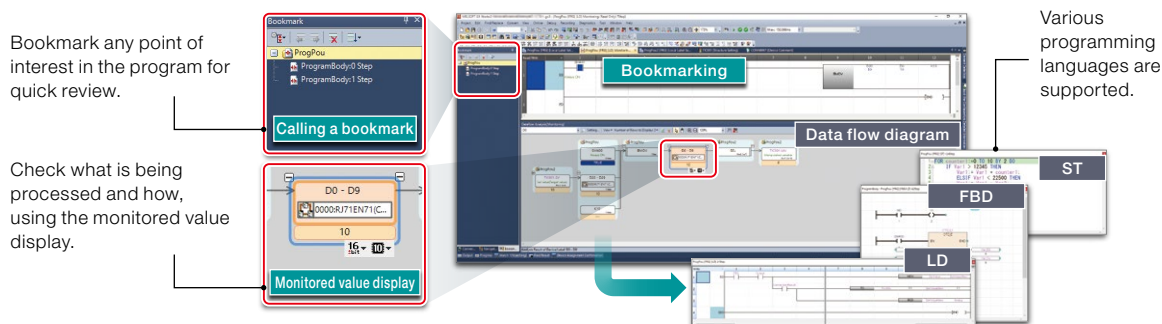

*1: The MX-F model is not supported.

Speed up program debugging and analysis

MX-R
MX-F

Easily identify problematic code using GX Works3 diagnostic function. Use the system monitor to check the module configuration and the error status of the system. View the event history to see errors and operations performed in the controller and motion in chronological order, including detailed error information, causes, and corrective actions.

Quickly debug and analyze complex programs with many labels and structures.

System monitor

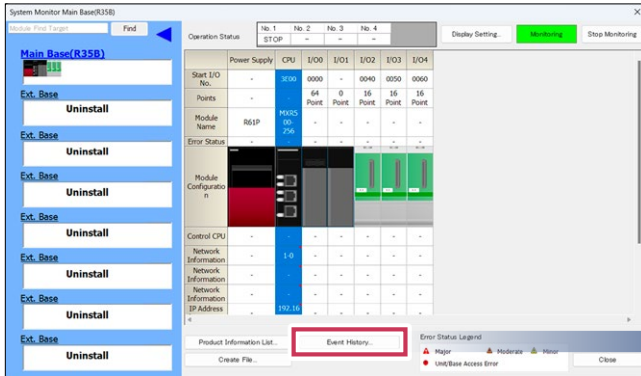

Event history

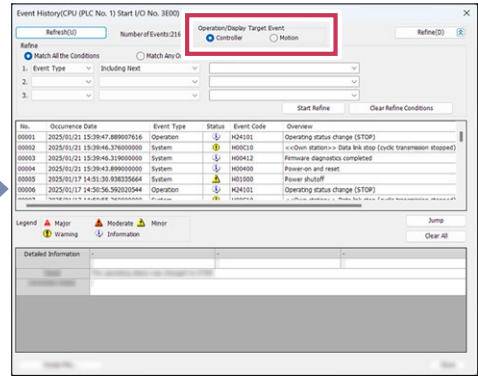

Analyze both sequence and motion programs simultaneously

One-stop search and analysis are available even for large programs with many labels and structures. Select data of interest (device or label) to visually display related data that affects changes in the selected data in a flow diagram. You can jump from the flow diagram to the corresponding part of the program, making it easy to identify the cause.

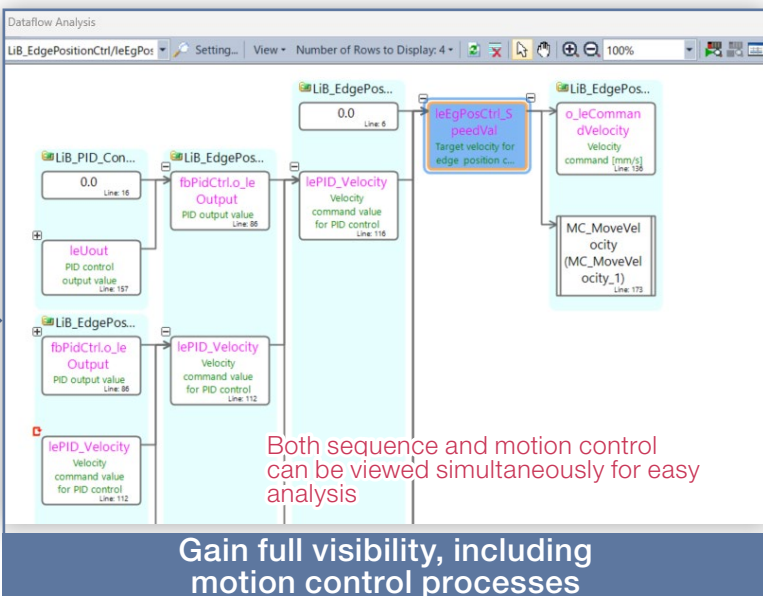
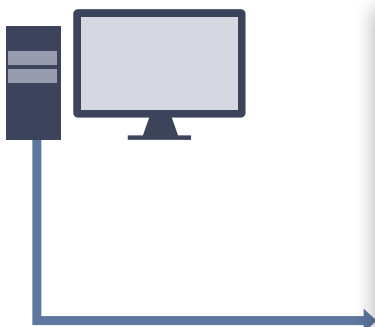

Data flow analysis

AI-assisted root cause analysis

Future support
MX-R

Future support
MX-F

Track device relationships that are not apparent in the program using AI. Efficiently debug issues where the program appears fine but the equipment stops without generating errors through AI-powered data flow analysis. For AI analysis, recording and logging files from normal operation of the equipment or machine are required.

Machine suddenly stopped.

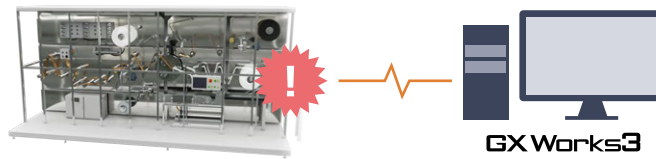

Before Analysis by conventional function

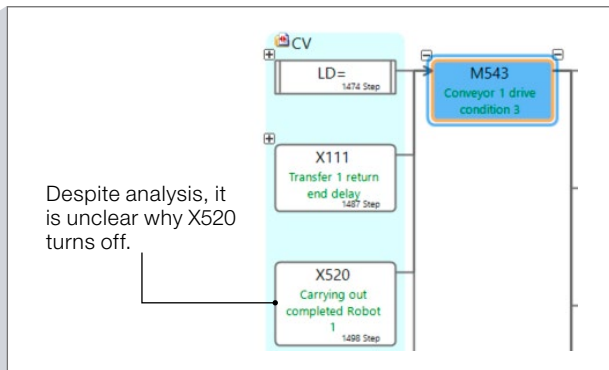
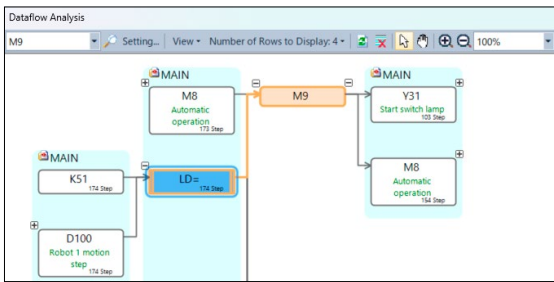

After Analysis by AI analysis function

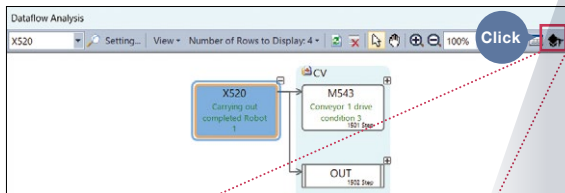

- AI Analysis...
- Import Analysis Result...
- Export Analysis Result...

Up to three of the most relevant results from the AI analysis are displayed. Let's check these to pinpoint the root cause.

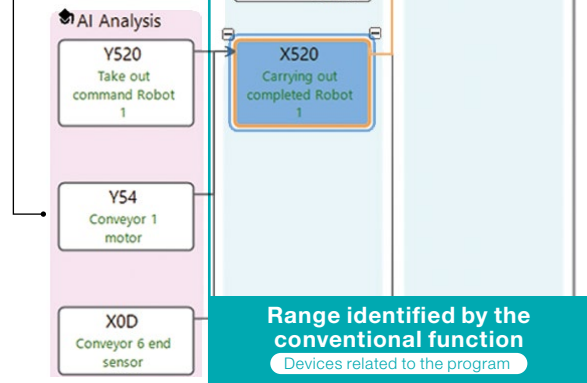

Range identified by the AI analysis (Devices not related to the program)

Automatically generate network parameters

MX-R
Future support
MX-F

Simply connect the engineering software to the master station and click a button on the screen to automatically detect the system configuration and generate network parameters. Even if the system configuration is changed, you can easily update the parameters with the same simple operation. This significantly reduces network setup time.

1 Example of actual system configuration (first time)

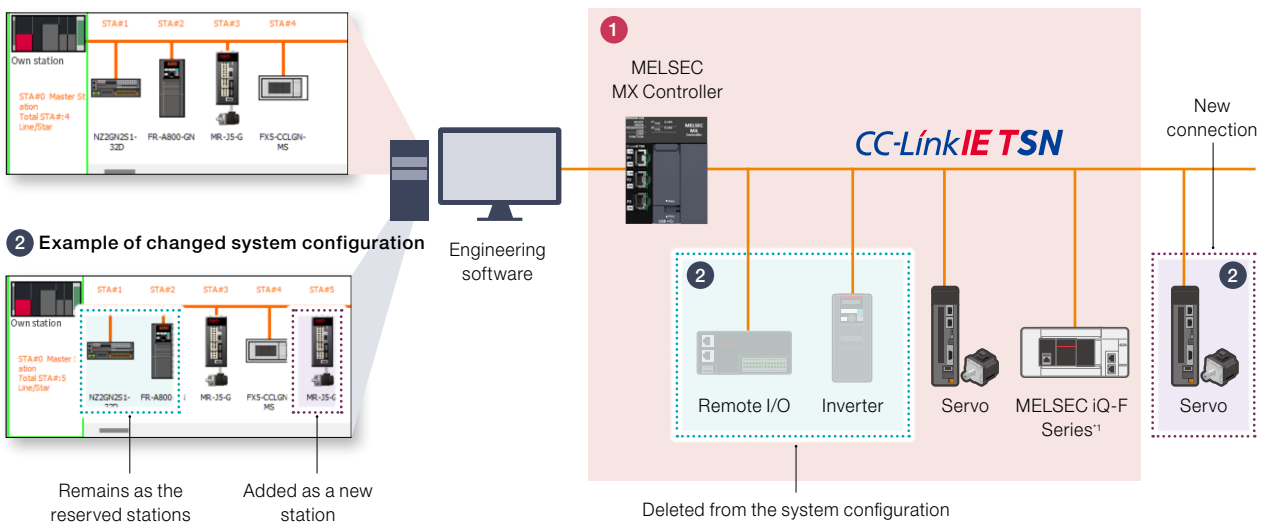

Reduce maintenance time with automatic parameter distribution

MX-R
MX-F

When a device is powered on or reconnected, parameters stored in the master station are automatically distributed to the device. Even after replacing a device, there is no need for individual parameter writing, ensuring a smooth and efficient replacement process.

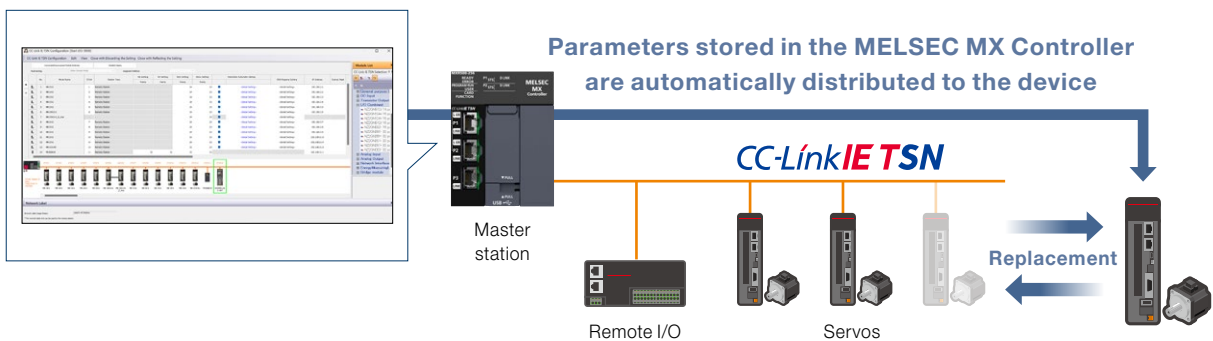

*1: Local stations will be supported in the future.

Digital transformation in factories

Security/information linkage



Achieve centralized management and sharing of valuable data

Boost work efficiency through data sharing and centralized management.

Information can be shared from each device to the IT system.

Protect assets from cyberattacks

MX-R

MX-F

Prevent eavesdropping and unauthorized access with encrypted communication and user authentication for both OT and IT environments, safeguarding your assets and preventing machine malfunctions.

The MELSEC MX Controller complies with IEC 62443-4-2, the security standard for protecting control systems from cyberattacks.

The controller detects program tampering at startup, preventing the execution of unauthorized programs.

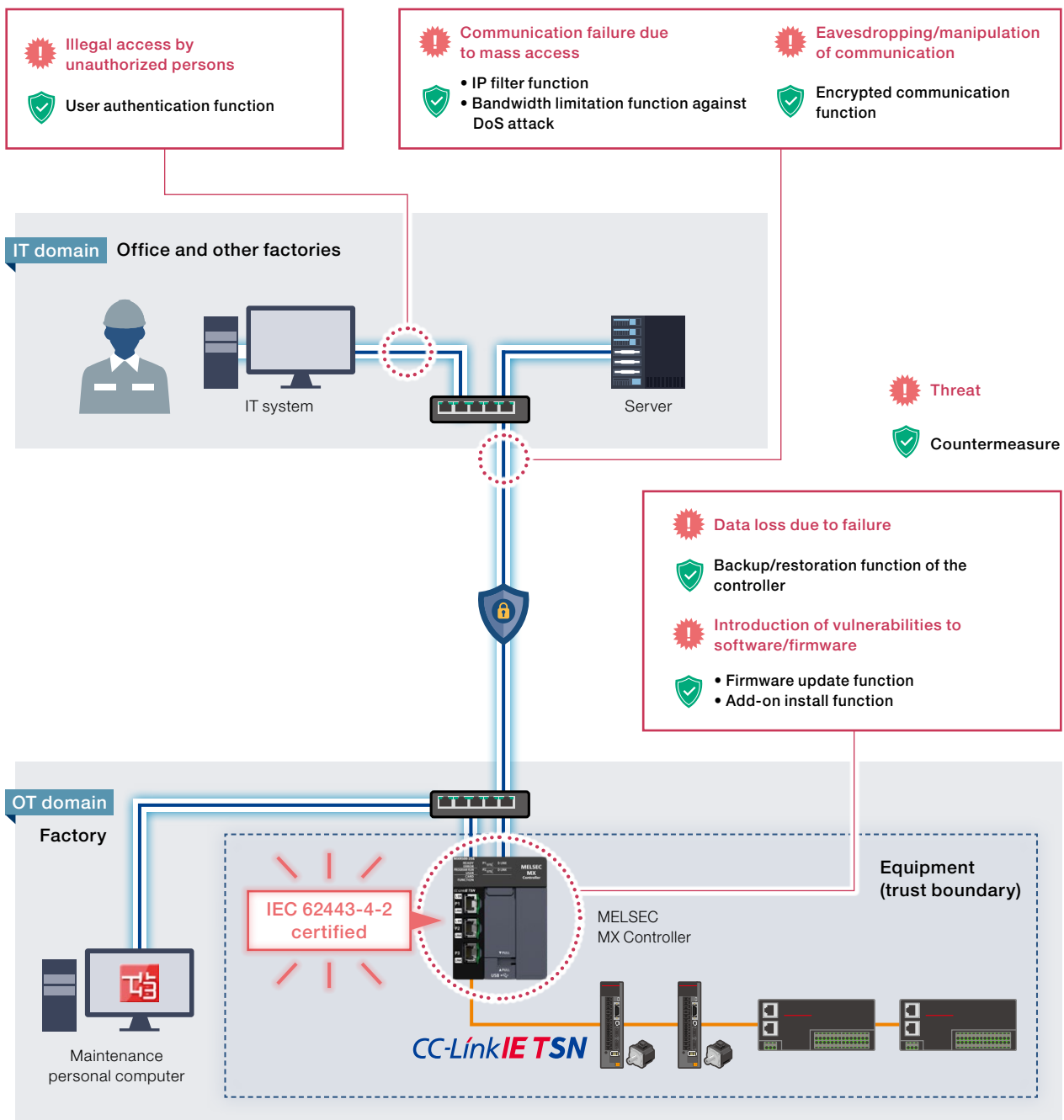

Security measures are required for the entire FA system.

Secure and seamless connection to IT system

Future support^{*1}
MX-R

Future support^{*1}
MX-F

The OPC UA server and client functions are included as standard. A single MELSEC MX Controller can communicate with the IT system (server function) and with OPC UA-compatible programmable controllers in the production line (client function).

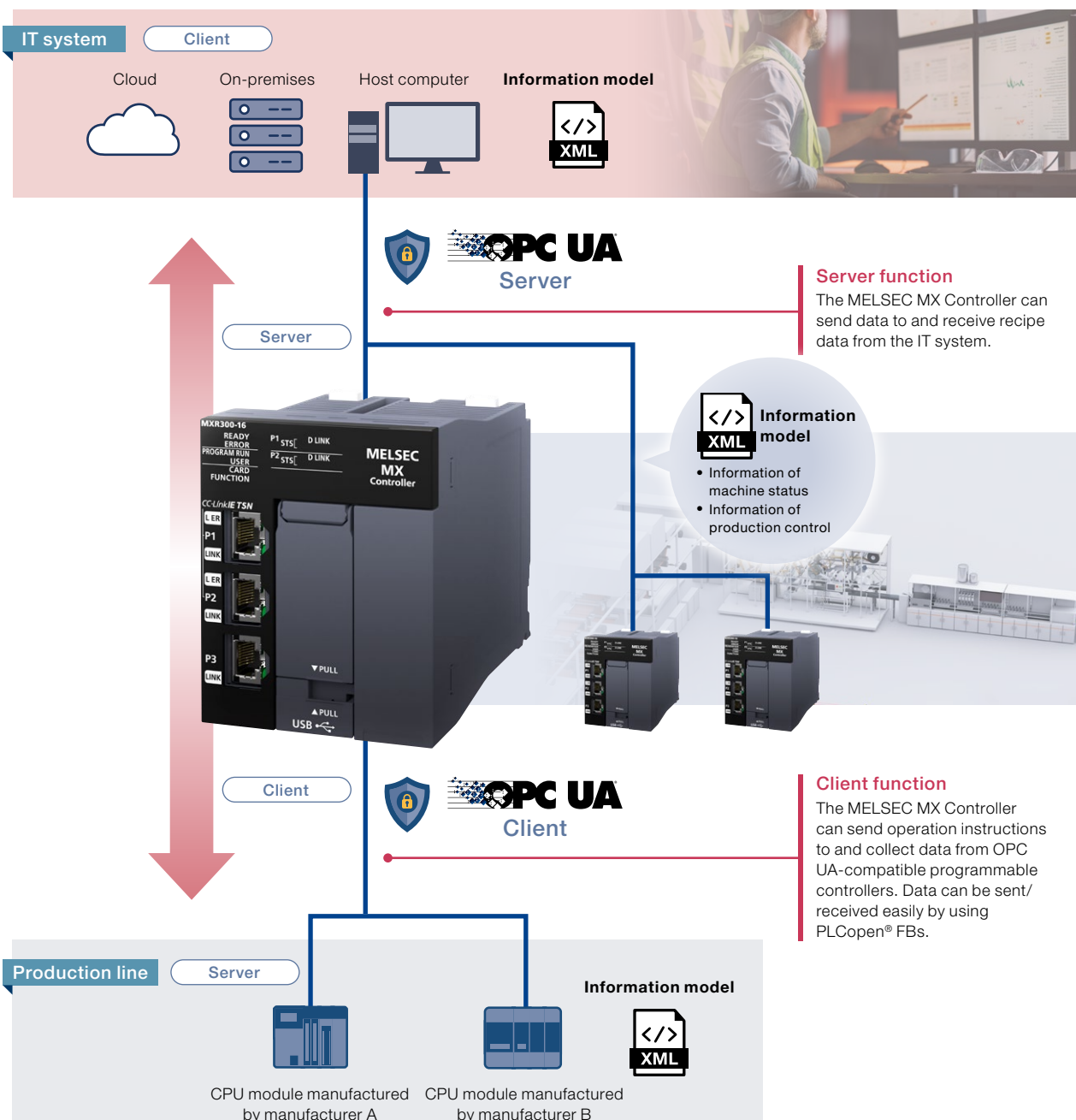

*1: The server function is supported. The client function and information models will be supported in the future.

Smart, centralized data management with network drive connectivity

Future support
MX-R

Future support
MX-F

Centrally manage data on a network drive and easily access it from anywhere as if it were your drive. After connecting to the network drive, you can store data just like the built-in memory or an SD card, allowing you to store large amounts of data for long periods of time.

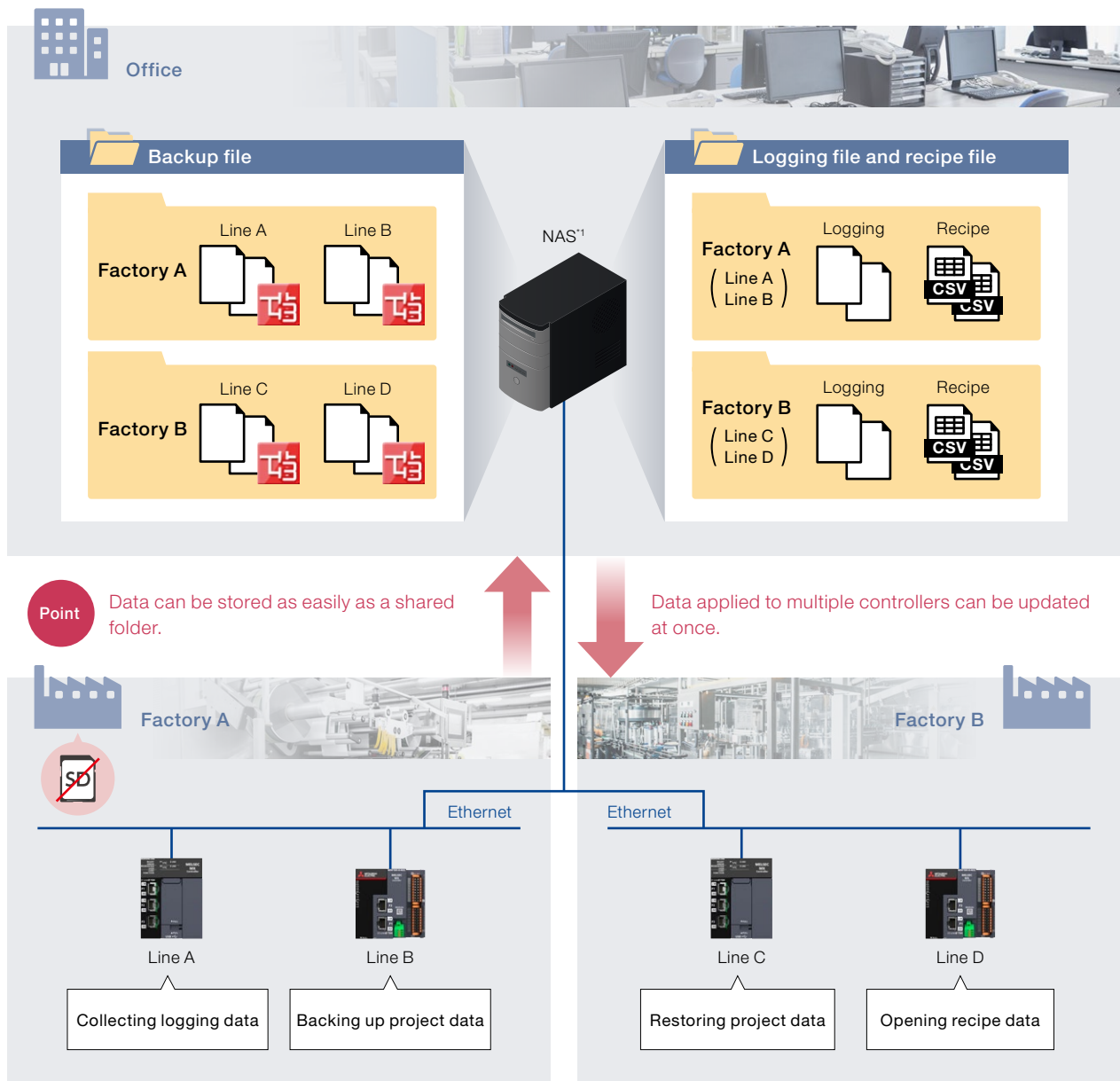

*1: Network Attached Storage

Monitor remote equipment status from anywhere

MX-R
Future support
MX-F

Use any browser-enabled device to monitor without restrictions on people or location.

The web server function allows you to monitor equipment status from various devices such as personal computers, tablets, and smartphones.

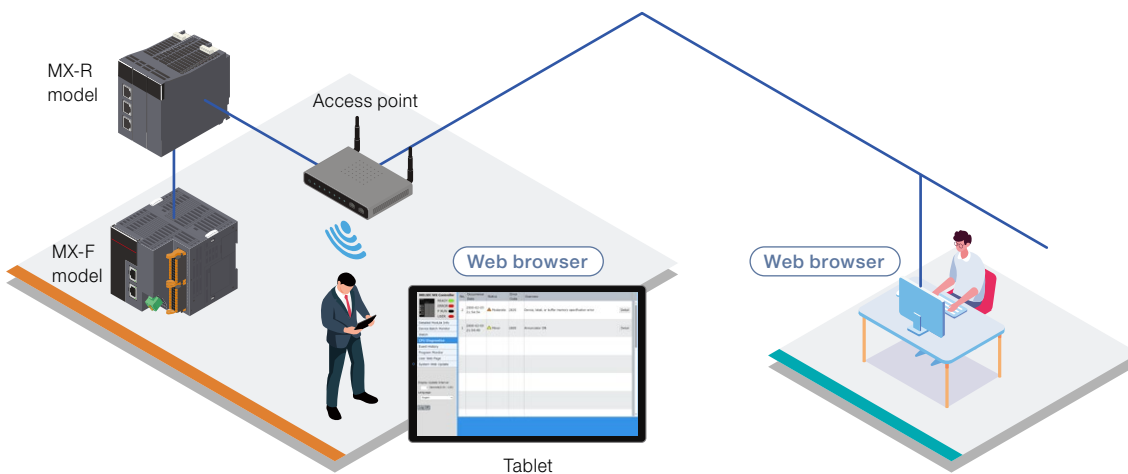

Factory Can be monitored without GX Works3

Office Can be monitored remotely

Quickly check the status of equipment around the time a problem occurs

View error details, program operating status, and device status in your browser for a quick initial assessment when a problem occurs.

Streamline maintenance by performing preliminary diagnostics prior to field investigation.

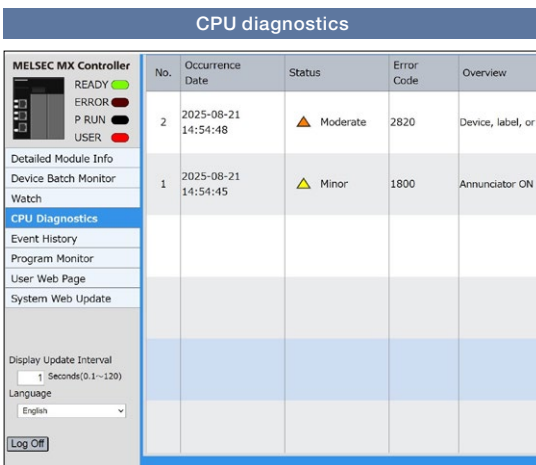

The error history and the cause of each error can be checked.

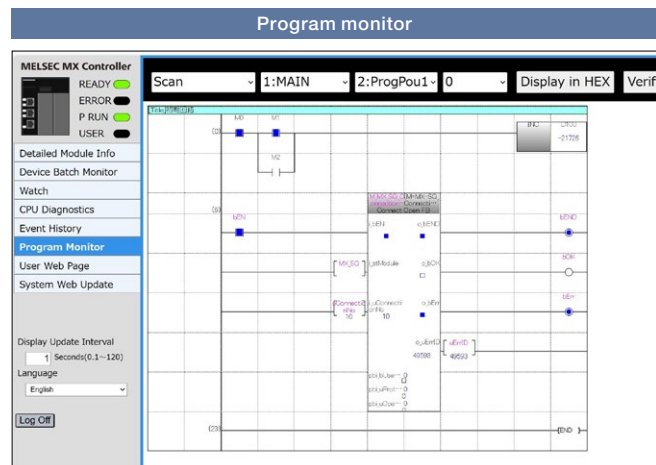

Easily create custom screens with the information you need

MX-R
Future support
MX-F

Design your original web pages

You can create original web pages for monitoring equipment status using numeric values, graphs, and images.

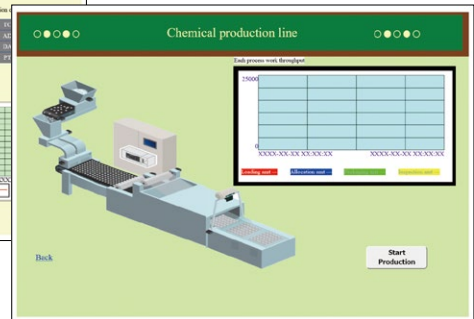
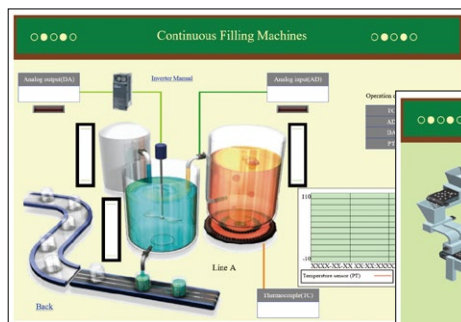

Point

View equipment status at a glance with your custom screen.

Simply drag and drop components

With our User Web Page Design Tool, you can create custom screens without any programming knowledge. Just place components and configure devices to build your screens.

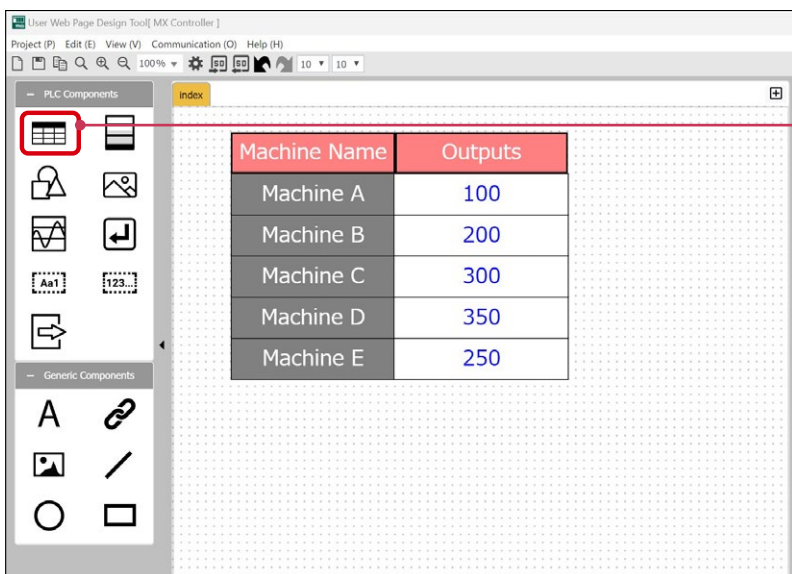

Drag and drop components from the list.

Free of charge
Design tool

Mitsubishi Electric's Digital Twin

Mitsubishi Electric has enhanced hardware/software coordination. Advanced simulations replicate real manufacturing processes in a virtual space through digital twins. Leveraging years of expertise, our software development will continue to evolve.

REAL

VIRTUAL

Low-speed
(second order)
Large scale

Production Line

STEP 1 Layout concept

» 3D simulator
MELSOFT Gemini

Achieves more productive facility design and virtual commissioning.

STEP 2 Machine review

» Logic simulator
MELSOFT Mirror

Desktop review of the control logic, including inter-process coordination and machine response

STEP 3 Mechanism design

» Development environment of model-based design
MATLAB® Simulink®

Control algorithm, physical model verification

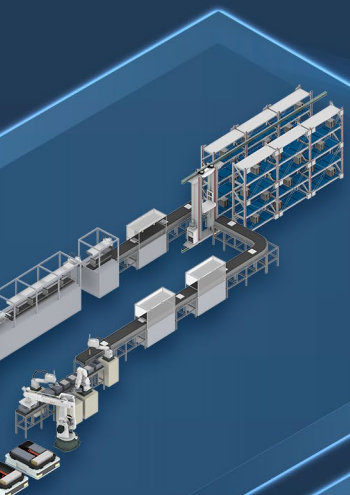

STEP 6 Line assembly and operation

» SCADA software
GENESIS64™

Visualizes everything on the factory floor.

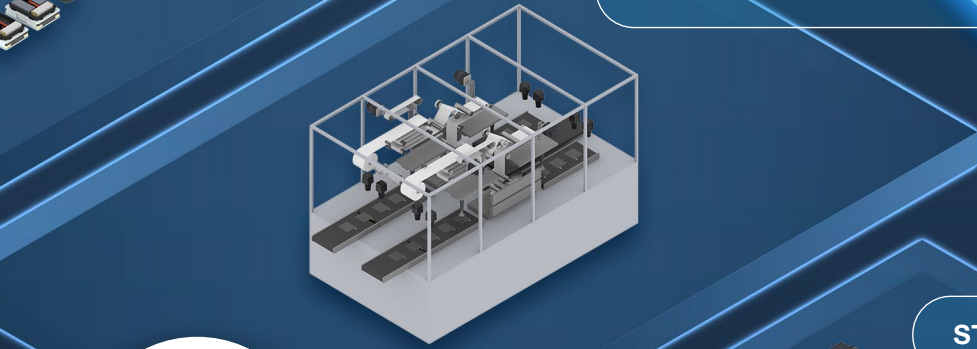

STEP 5 Machine verification

» Data science tool
MELSOFT MaiLab

Improves productivity by analyzing and diagnosing data using AI and predictive maintenance.

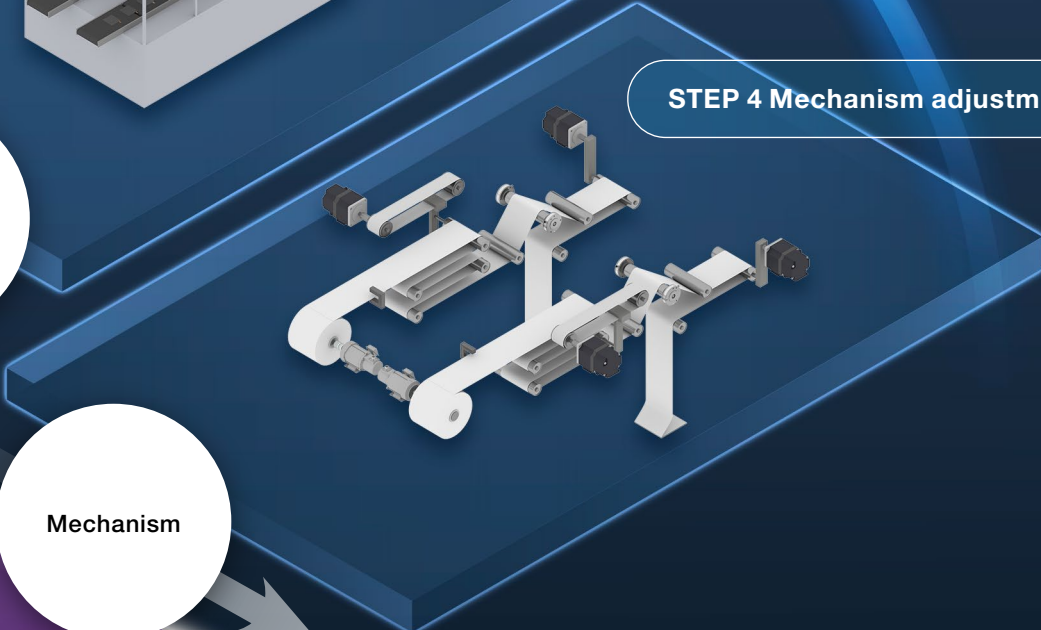

STEP 4 Mechanism adjustment

Machines

Mechanism

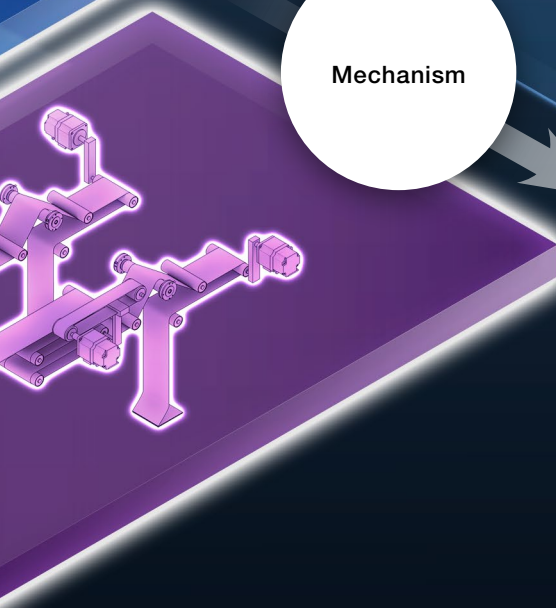

High-speed
(ms order)
Small scale

» Engineering software

MELSOFT GX Works3

Integrated engineering environment

MELSOFT GX VideoViewer Pro

Automatically extracts differences from videos and analyzes an error cause by AI analysis.

MELSOFT GX LogViewer

Waveform data check and simple analysis

Leverage the fusion of digital and hardware with our digital twin environment

Future support

MX-R

Future support

MX-F

Simulation technologies such as MELSOFT Gemini and MELSOFT Mirror are integrated with Mitsubishi Electric's hardware, field and control expertise, and open innovation, allowing you to front-load your facility design, build highly productive production systems and achieve accurate digital twin.



3D simulator

MELSOFT Gemini

Mechanical behavior display

Sensor response



3D simulator that drives the digital transformation of facility design work

The operation of production line and facility is visualized in 3D space. As a comprehensive facility design platform that can be used in every phase, from conceptual through detailed design phases, it serves as a hub for communication and data sharing across departments. It helps you build highly productive systems while significantly reducing costs.

Benefits of MELSOFT Gemini

One tool for all design phases

From conceptual to detailed design, MELSOFT Gemini enables cost-effective design operations at every stage.

Communication and data hub

MELSOFT Gemini facilitates accurate communication and information transfer between conceptual, mechanical, and control design phases, promoting front-loading and reducing rework.

Leverage simulation data for real-world improvements

Reduce hardware engineering time by input/output of control programs based on MELSOFT Gemini simulation data.

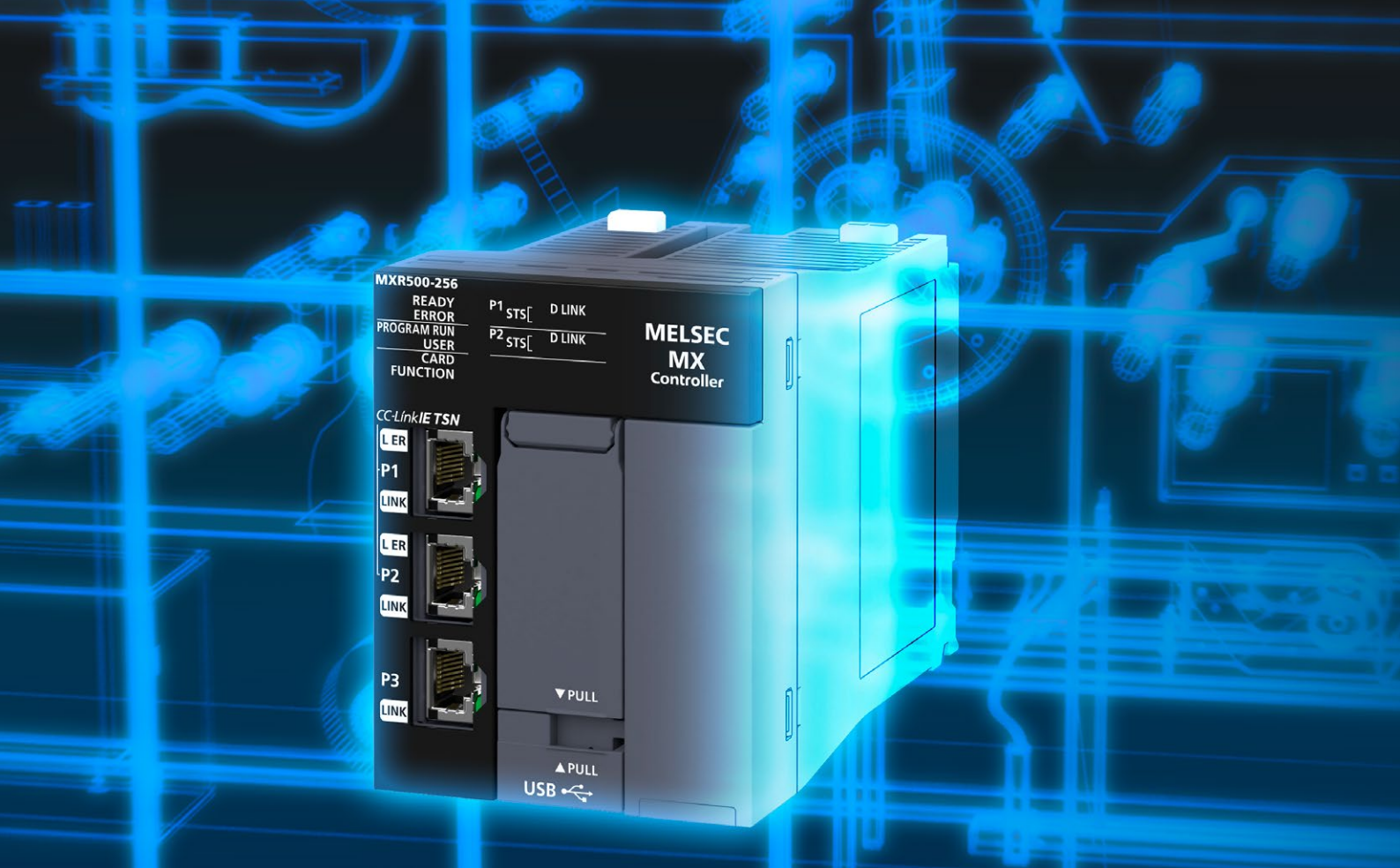

Logic simulator

MELSOFT Mirror

Control logic operation

Machine response operation



Run control programs in a virtual environment

Verify equipment behavior using actual control programs without the need for physical hardware.

Test the interactions of multiple processes and programs for large-scale systems, accelerating equipment development.

Benefits of MELSOFT Mirror

You can verify behavior without physical hardware

Test new equipment virtually before actual implementation.

You can verify complex control processes

Verify processes and interlocks across multiple processes and stations by combining different control programs.

You can verify anytime, anywhere, with multiple people

Perform verification from remote locations using the same virtual equipment.

Share equipment operation in real time to make verification more efficient.

Advance front-loading with MATLAB®/ Simulink® for model-based development (MBD) and automatic code generation

MX-R

MX-F

FBs (structured text language) are automatically generated from control models, such as tension control and PID, verified by MATLAB®/Simulink®. This reduces coding time and effort and minimizes errors. The behavior of the generated FBs can be verified using the GX Works3 simulator¹, MELSOFT Mirror¹, or physical hardware. Based on verification results, you can identify and correct errors at an early stage.

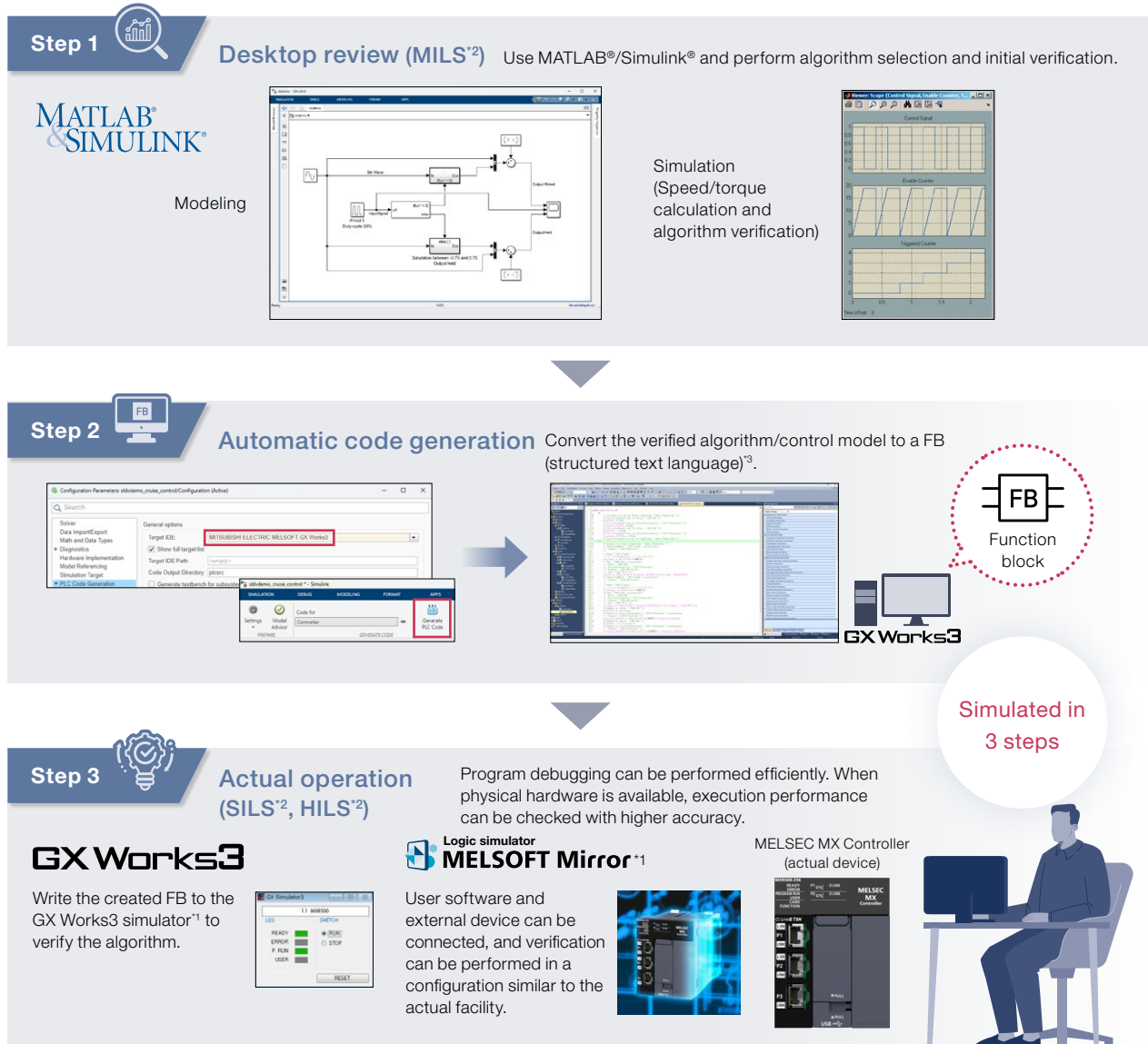

¹: Future support

²: MILS: Model-in-the-Loop Simulation (Method for executing a system in a simulation environment using a modeled system)

SILS: Software-in-the-Loop Simulation (Method for executing software in a simulation environment without using actual hardware)

HILS: Hardware-in-the-Loop Simulation (Method for executing a system in a simulation environment using actual hardware)

³: Convert to a function block using Simulink® PLC Coder™.

Basic system configuration (MX-R model)

The MELSEC MX Controller (MX-R model) is mounted on the MELSEC iQ-R Series main base unit. This product can be used in combination with the products listed in the "List of devices that support MELSEC MX Controller (MX-R model)" below.

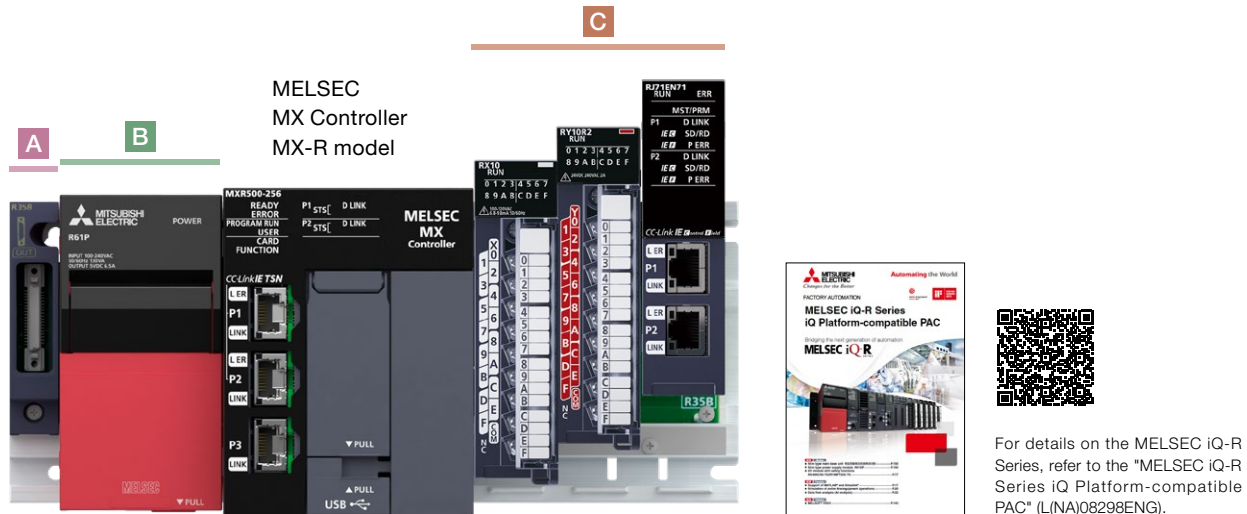

List of devices that support MELSEC MX Controller (MX-R model)

A Base unit

Main base	R33B, R35B, R38B, R312B	
Extension base	Extension base	R65B, R68B, R612B
	Extended temperature range extension base	R610B-HT
Extension cable	RC06B, RC12B, RC30B, RC50B, RC100B	

B Power supply module

Power supply	R61P, R62P ¹⁾ , R63P, R64P, R69P
Redundant power supply	R63RP, R64RP, R69RP

C Modules that support MELSEC MX Controller (MX-R model)

I/O module

AC input	RX10
	RX10-TS
	RX28
DC input	RX40C7, RX41C4, RX42C4
	RX40C7-TS, RX41C4-TS, RX70C4, RX71C4, RX72C4
	RX40PC6H, RX40NC6H
DC high-speed input	RX41C6HS, RX61C6HS
	RX40NC6B
Input with diagnostic functions	RY10R2
Contact output	RY10R2-TS
	RY18R2A
Triac output	RY20S6
Transistor output	RY40NT5P, RY41NT2P, RY42NT2P, RY40PT5P, RY41PT1P, RY42PT1P
	RY40NT5P-TS, RY41NT2P-TS, RY40PT5P-TS, RY41PT1P-TS
	RY41NT2H, RY41PT2H
Transistor high-speed output	RY40PT5B
Output with diagnostic functions	RH42C4NT2P
I/O combined	

Analog module

Analog-digital conversion	R60AD4, R60AD18, R60ADV8
High-speed analog-digital conversion	R60ADH4
Channel isolated analog-digital conversion	R60AD8-G, R60AD16-G
Channel isolated analog input module	R60AD6-DG
Digital-analog conversion	R60DA4, R60DA18, R60DAV8
High-speed digital-analog conversion	R60DAH4
Channel isolated digital-analog conversion	R60DA8-G, R60DA16-G

Temperature input module, temperature control module

Channel isolated thermocouple input	R60TD8-G
Channel isolated RTD input	R60RD8-G
Temperature control	R60TCTR2T2TT2, R60TCTR2T2TT2BW, R60TCRT4, R60TCRT4BW
	R60TCTR2T2-TS, R60TCRT4-TS

High-speed counter module, isolated pulse input module, flexible high-speed I/O control module

High-speed counter	RD62P2, RD62D2, RD62P2E
Channel isolated pulse input	RD60P8-G
Flexible high-speed I/O control	RD40PD01

Positioning module

Positioning	RD75P2, RD75P4, RD75D2, RD75D4
-------------	--------------------------------

Information module

Ethernet interface with built-in CC-Link IE	RJ71EN71
Serial communication	RJ71C24, RJ71C24-R2, RJ71C24-R4
MES interface	RD81MES96N
GP-IB interface	RJ71GB91

Network module

CC-Link IE TSN	RJ71GN11-T2
	RJ71GN11-SX
	RJ71GN11-EIP
CC-Link IE Controller Network	RJ71GP21-SX
	RJ71GP21S-SX
CC-Link IE Field Network	RJ71GF11-T2
CC-Link system master/local	RJ61BT11
AnyWireASLINK master	RJ51AW12AL
CANopen [®]	RJ71CN91
DeviceNet master/slave	RJ71DN91
BACnet [®]	RJ71BAC96

Energy measuring module

Energy measuring	RE81WH
------------------	--------

Blank cover module

Blank cover	RG60
-------------	------

SD memory card

SD memory card	NZ1MEM-2GBSD, NZ1MEM-4GBSD, NZ1MEM-8GBSD, NZ1MEM-16GBSD
----------------	---

Battery

Battery	FX3U-32BL
---------	-----------

*1: MXR500-□: Can be used only on the extension base unit.
MXR300-□: Can be used on the R33B, R35B, and extension base unit.

System configuration example

■ MELSEC MX Controller (MX-R model)

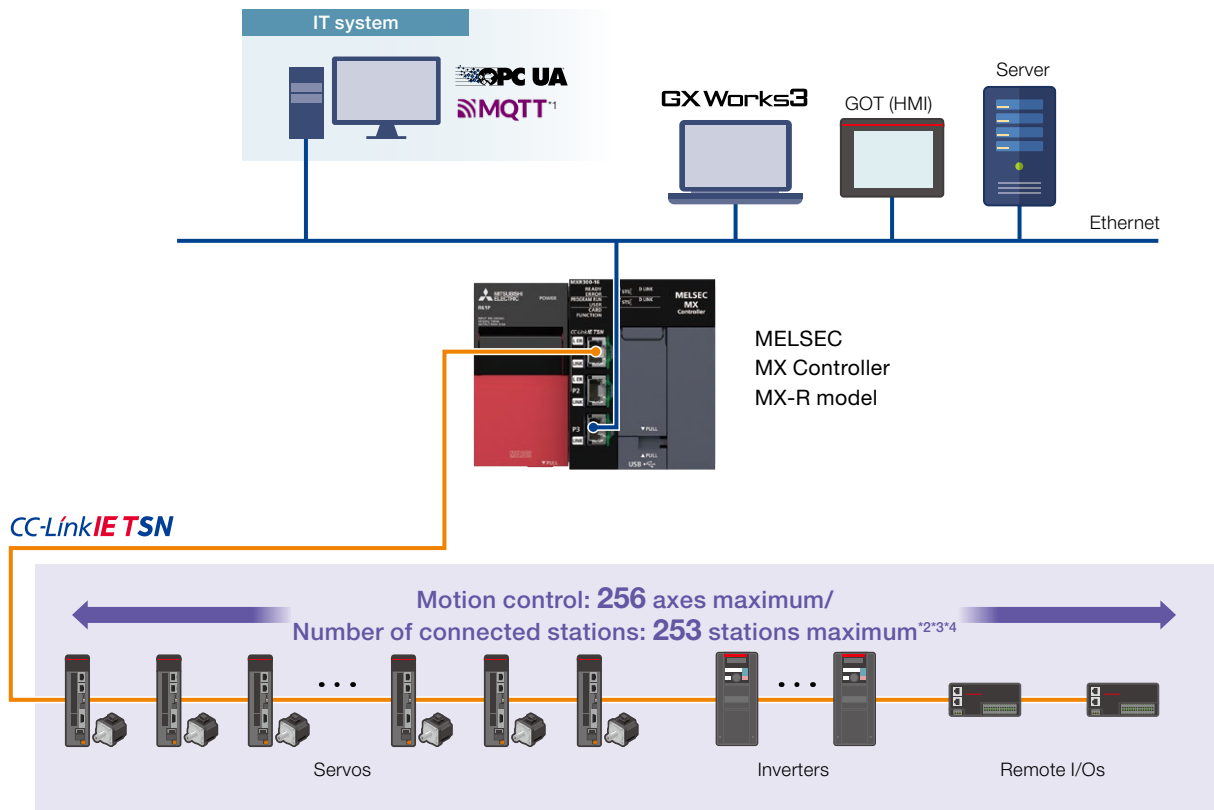

*1: Future support

*2: The multi-axis servo amplifier can control multiple axes with one station occupied. (The number of virtual axes is not included in the number of controllable axes.)

*3: Device stations supporting connections to 253 stations will be available in the future. For details, refer to the Technical Bulletin (FA-A-0451).

*4: Only the servo can execute motion control.

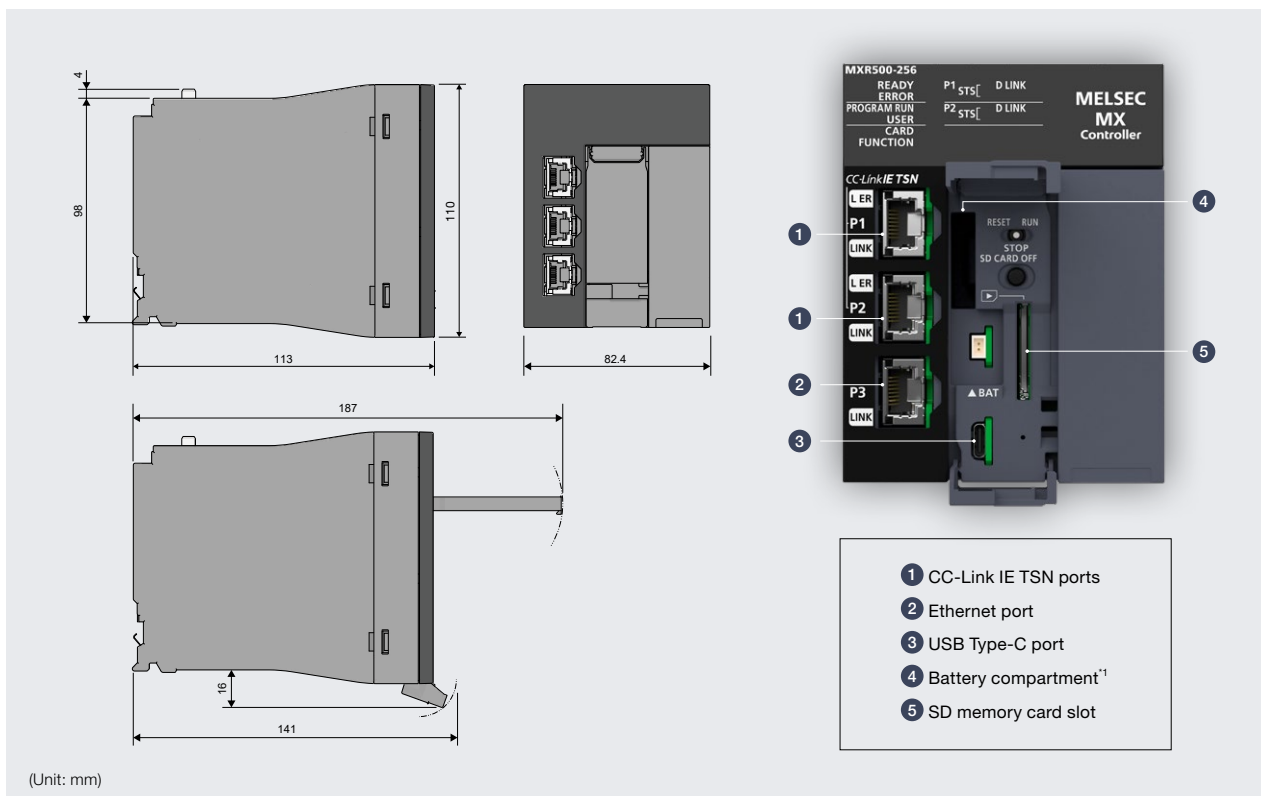

*1: Clock data can be retained during a power failure for 11 days or more. (Latch device/latch label contents can be retained during a power failure without the battery.)

Basic system configuration (MX-F model)

The MELSEC MX Controller (MX-F model) can be used with an extension connector type I/O module, MELSEC iQ-F Series expansion adapter and extension module, and intelligent function module.

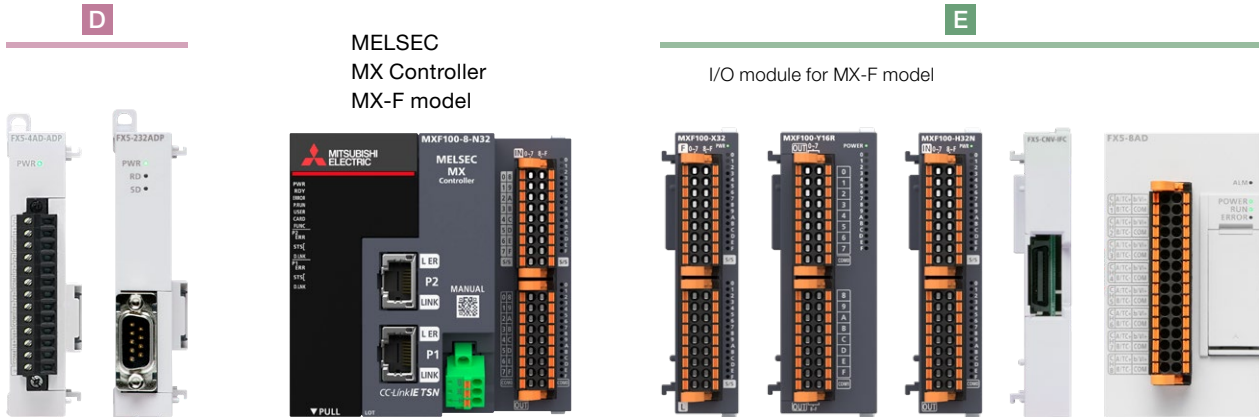

List of devices that support MELSEC MX Controller (MX-F model)

D Expansion adapter

Analog		Communication	
Analog input	FX5-4AD-ADP	RS-232 communication	FX5-232ADP
RTD temperature sensor input	FX5-4AD-PT-ADP	RS-485 communication	FX5-485ADP
Thermocouple temperature sensor input	FX5-4AD-TC-ADP		
Analog output	FX5-4DA-ADP		
Analog I/O	FX5-4A-ADP		

E Extension module

I/O module for MX-F model ¹		Intelligent function module	
Input	MXF100-X32	• High-speed counter ²	
Output	MXF100-Y16R MXF100-Y32N MXF100-Y32P	High-speed counter	FX5-2HC/ES
Input/output	MXF100-H32N MXF100-H32P	• Analog ²	
Input	FX5-8EX/ES FX5-16EX/ES	Multiple input	FX5-8AD
Output	FX5-8EYR/ES FX5-16EYR/ES FX5-8EYT/ES FX5-16EYT/ES FX5-8EYT/ESS FX5-16EYT/ESS	Analog input	FX5-4AD
Input/output	FX5-16ER/ES FX5-16ET/ES FX5-16ET/ESS	Analog output	FX5-4DA
Powered I/O	FX5-32ER/DS FX5-32ET/DS FX5-32ET/DSS	Temperature control	FX5-4LC
High-speed pulse input/output	FX5-16ET/ES-H FX5-16ET/ESS-H	• Information/Network ²	
		CC-Link IE TSN master/local	FX5-CCLGN-MS
		CC-Link system master/intelligent device	FX5-CCL-MS
		Ethernet	FX5-ENET
		EtherNet/IP™	FX5-ENET/IP, FX5-EIP
		Conversion module and others	
		Extension power supply unit	FX5-C1PS-5V
		Connector conversion module	FX5-CNV-IFC FX5-30EC
		Extension cable ³	FX5-65EC
		Conversion adapter	FX5-CNV-BC

SD memory card		Battery	
SD memory card	NZ1MEM-2GBSD, NZ1MEM-4GBSD, NZ1MEM-8GBSD, NZ1MEM-16GBSD	Battery	FX3U-32BL



For details on the MELSEC iQ-F Series, refer to the "MELSEC iQ-F Series iQ Platform-compatible PLC" (L(NA)08428ENG).

¹: Some MELSEC iQ-F Series I/O modules can also be added. For details, refer to the "MELSEC MX Controller (MX-F Model) User's Manual" (SH(NA)-082634ENG).

²: When the extension cable type module is used, the FX5-CNV-IFC or FX5-C1PS-5V is required.

³: This module is available after connector conversion with the FX5-CNV-IFC or FX5-C1PS-5V.

System configuration example

■ MELSEC MX Controller (MX-F model)

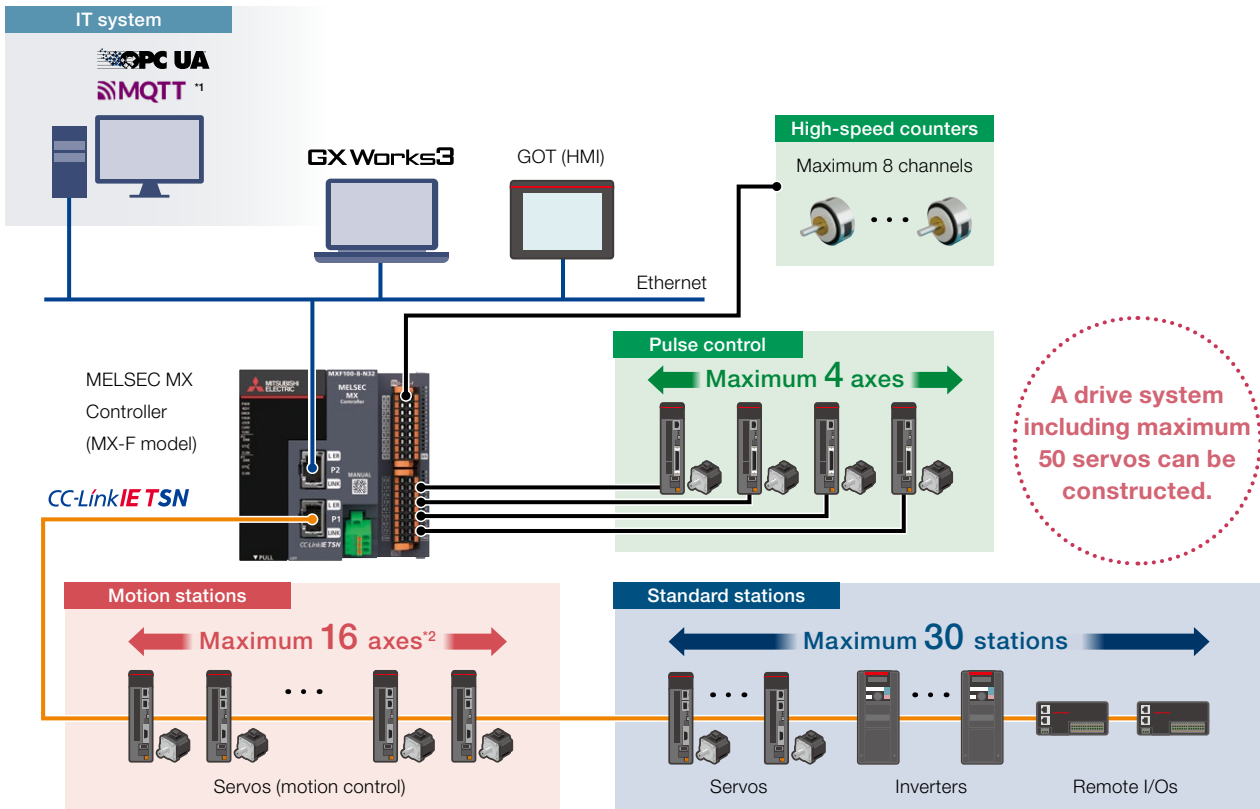

*1: Future support

*2: The number of virtual axes is not included in the number of controllable axes.

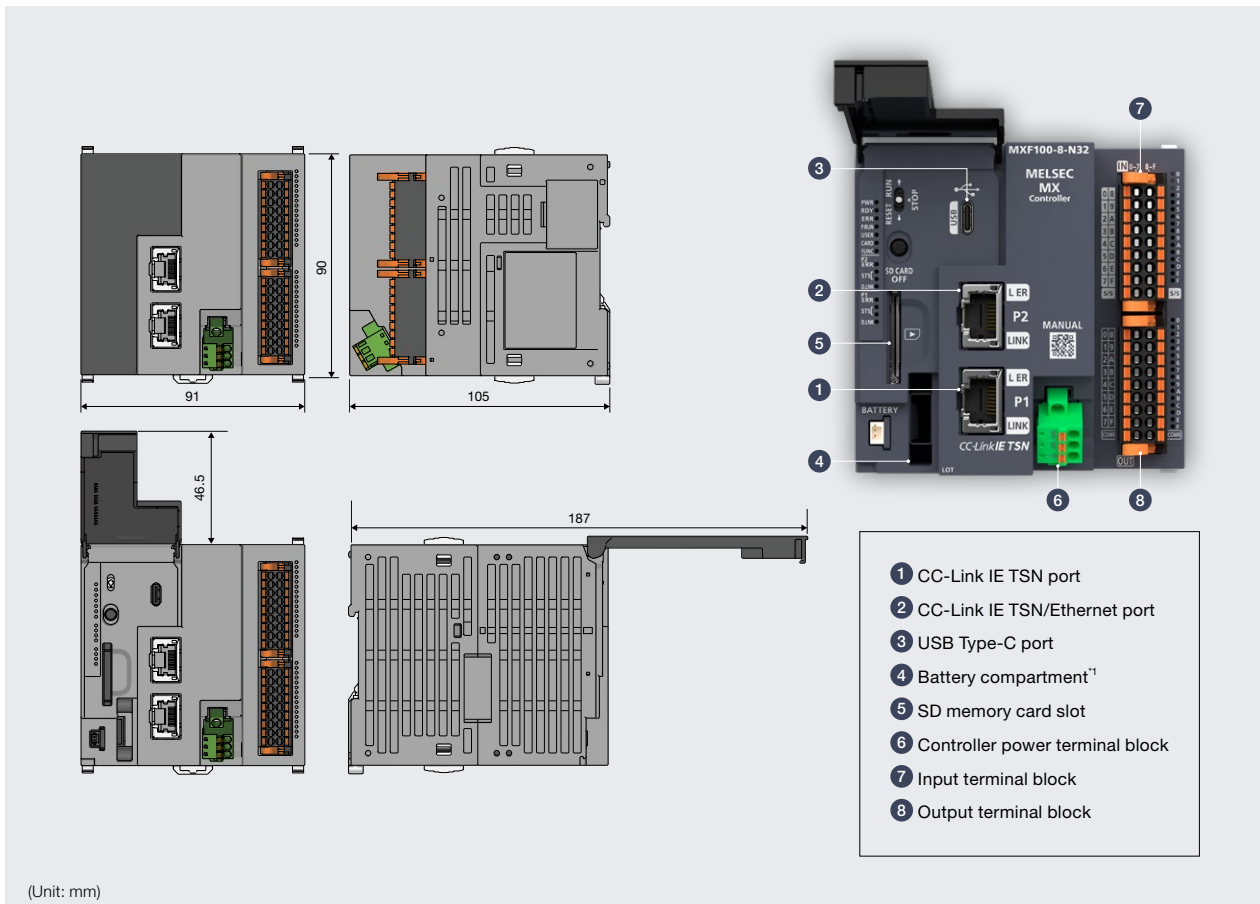

*1: Clock data can be retained during a power failure for 11 days or more. (Latch device/latch label contents can be retained during a power failure without the battery.)

■ Block type remote module

Input module

[Spring-clamp terminal block]

NZ2GN2S1-16D



NZ2GN2S1-32D



[Screw terminal block]

NZ2GN2B1-16D



NZ2GN2B1-32D



[Sensor connector (e-CON)]

NZ2GNCE3-32D



[40-pin connector]

NZ2GNCF1-32D



Output module

[Spring-clamp terminal block]

NZ2GN2S1-16T



NZ2GN2S1-16TE



[Screw terminal block]

NZ2GN2B1-16T



NZ2GN2B1-16TE



NZ2GN2S1-32T



NZ2GN2S1-32TE



NZ2GN2B1-32T



NZ2GN2B1-32TE



[40-pin connector]

NZ2GNCF1-32T



I/O combined module

[Spring-clamp terminal block]

NZ2GN2S1-32DT



NZ2GN2S1-32DTE



[Screw terminal block]

NZ2GN2B1-32DT



NZ2GN2B1-32DTE



[Sensor connector (e-CON)]

NZ2GNCE3-32DT



Analog input module

[Spring-clamp terminal block]

NZ2GN2S-60AD4



[Screw terminal block]

NZ2GN2B-60AD4



Analog output module

[Spring-clamp terminal block]

NZ2GN2S-60DA4



[Screw terminal block]

NZ2GN2B-60DA4



Waterproof/dustproof type (IP67) remote module

Input module

[Waterproof connector]

NZ2GN12A4-16D



NZ2GN12A4-16DE



Output module

[Waterproof connector]

NZ2GN12A2-16T



NZ2GN12A2-16TE



I/O combined module

[Waterproof connector]

NZ2GN12A42-16DT



NZ2GN12A42-16DTE



Industrial switching hub

Industrial switching hub

NZ2MHG-TSNT4



NZ2MHG-TSNT8F2



For details on the AC servo, refer to the "Mitsubishi Electric AC Servo System MELSERVO-J5" (L(NA)03179ENG).



For details on the AC servo MELSERVO-JET, "Mitsubishi Electric AC Servo System MELSERVO-JET" (L(NA)03187).



For details on the general-purpose inverter, refer to the "INVERTER FAMILY" (L(NA)06036).



For details on the GOT2000 Series, refer to the "Graphic Operation Terminal GOT2000 Series" (L(NA)08270ENG).



Specifications/Function list

When adopting this product, please read the information in the product manual, including specifications, available modules, and restrictions.

General specifications

■ MX-R model

Item	Specifications					
Operating ambient temperature	0...55°C					
Storage ambient temperature	-25...75°C					
Operating ambient humidity	5...95% RH, non-condensing					
Storage ambient humidity	5...95% RH, non-condensing					
Vibration resistance	Compliant with JIS B 3502 and IEC 61131-2	-	Frequency	Constant acceleration	Half amplitude	Number of sweeps
		Under intermittent vibration	5...8.4 Hz	-	3.5 mm	10 times each in X, Y, and Z directions
			8.4...150 Hz	9.8 m/s ²	-	
		Under continuous vibration	5...8.4 Hz	-	1.75 mm	-
	8.4...150 Hz	4.9 m/s ²	-			
Shock resistance	Compliant with JIS B 3502 and IEC 61131-2 (147 m/s ² , 3 times each in X, Y, and Z bidirections)					
Operating atmosphere	No corrosive gases ⁴ and flammable gases, less conductive dust					
Operating altitude ¹	0...2000 m					
Installation location	Inside an indoor-use control panel					
Overvoltage category ²	II or less					
Pollution degree ³	2 or less					

*1: Do not use or store the controller under pressure higher than the atmospheric pressure of altitude 0 m. Doing so may cause malfunction.

*2: This indicates the section of the power supply to which the equipment is assumed to be connected between the public electrical power distribution network and the machinery within premises. Category II applies to equipment for which electrical power is supplied from fixed facilities. The surge voltage withstand level for up to the rated voltage of 300 V is 2500 V.

*3: This index indicates the degree to which conductive material is generated in terms of the environment in which the equipment is used. Pollution degree 2 is when only non-conductive pollution occurs. A temporary conductivity caused by condensation must be expected occasionally.

*4: When using the controller in the environment with the corrosive gases, use the special coated products having improved resistance to the environment of a certain degree of corrosive gas concentration specified in IEC 60721-3-3: 1994 3C2.

For details on the special coated products, please consult your local Mitsubishi Electric representative.

■ MX-F model

Item	Specifications				
Operating ambient temperature ¹	0...55°C, non-freezing				
Storage ambient temperature	-25...75°C, non-freezing				
Operating ambient humidity	5...95% RH, non-condensing ²				
Storage ambient humidity	5...95% RH, non-condensing				
Vibration resistance ^{3,4}	-	Frequency	Constant acceleration	Half amplitude	Number of sweeps
	Installed on DIN rail	5...8.4 Hz	-	1.75 mm	10 times each in X, Y, and Z directions (total 80 minutes in each direction)
		8.4...150 Hz	4.9 m/s ²	-	
Shock resistance ³	147 m/s ² , Duration of action: 11 ms, 3 times each in X, Y, and Z bidirections by sine half-wave pulse				
Noise immunity	By noise simulator at noise voltage of 1000 Vp-p, noise width of 1 μs and period of 30...100 Hz				
Grounding	Grounding resistance of 100Ω or less (Common grounding with a heavy electrical system is not allowed) ⁵				
Operating atmosphere	No corrosive gases and flammable gases, less conductive dust				
Operating altitude ⁶	0...2000 m				
Installation location	Inside a control panel ⁷				
Overvoltage category ⁸	II or less				
Pollution degree ⁹	2 or less				

*1: Input/output derating is required. For details, refer to the manual.

*2: When used in a low-temperature environment, use in an environment with no sudden temperature changes. When there are sudden temperature changes because of opening/closing of the control panel or other reasons, condensation may occur, which may cause a fire, fault, or malfunction. Furthermore, use an air conditioner in dehumidifier mode to prevent condensation.

*3: The criterion is shown in IEC 61131-2.

*4: When the system has equipment which specification values are lower than above mentioned vibration resistance specification values, the vibration resistance specification of the whole system is corresponding to the lower specification.

*5: For details on the grounding, refer to the manual.

*6: The controller cannot be used at a pressure higher than the atmospheric pressure to avoid damage.

*7: The controller system is assumed to be installed in an environment equivalent to indoor.

*8: This indicates the section of the power supply to which the equipment is assumed to be connected between the public electrical power distribution network and the machinery within premises. Category II applies to equipment for which electrical power is supplied from fixed facilities. The surge voltage withstand level for up to the rated voltage of 300 V is 2500 V.

*9: This index indicates the degree to which conductive material is generated in terms of the environment in which the equipment is used. Pollution degree 2 is when only non-conductive pollution occurs. A temporary conductivity caused by condensation must be expected occasionally.

Performance specifications

●: Supported, -: Not supported

Item		MXR300-16	MXR300-32	MXR300-64	MXR500-128	MXR500-256	MXF100-8-N32 MXF100-8-P32	MXF100-16-N32 MXF100-16-P32
Operation control method		Repetitive operation of stored programs						
I/O control mode		Refresh mode (The direct access input/output is available by specifying the direct access input/output (DX, DY).)						
Programming language		<ul style="list-style-type: none"> · Ladder diagram (LD) · Structured text (ST) · Function block diagram (FBD/LD) 						
Extended programming language		<ul style="list-style-type: none"> · Function block (FB) · Label programming 						
Program execution type		Initial, scan, fixed scan, interrupt, and standby						
Number of I/O points		4K points (4096 points)					512 points	
Memory capacity	Program memory	100 MB			150 MB		30 MB	
	Program cache memory	40 MB			80 MB		12 MB	
	Device/label memory	128 MB			256 MB		8 MB	
	Data memory	30 MB			60 MB		15 MB	
Online change		●						
Processing speed	Double-precision floating-point processing	0.63 ns...			0.46 ns...		2.50 ns...	
	Instruction processing time	LD instruction	0.38 ns...			0.28 ns...		1.25 ns...
Number of occupied I/O points		64 points (CC-Link IE TSN function part: 32 points, motion function part: 32 points)						-
Number of slots occupied by a module		3 slots						-
Peripheral connection port								
USB port		USB 2.0 High Speed (Type-C) × 1						
Ethernet port		100BASE-TX × 1						- ¹
CC-Link IE TSN port		1000BASE-T/100BASE-TX × 2						1000BASE-T/100BASE-TX × 2 ¹

*1: One of the CC-Link IE TSN ports can be switched to the Ethernet port.

●: Supported, -: Not supported

Item		MXR300-16	MXR300-32	MXR300-64	MXR500-128	MXR500-256	MXF100-8-N32 MXF100-8-P32	MXF100-16-N32 MXF100-16-P32		
Memory interface										
SD memory card		SD/SDHC memory card								
Motion control specifications										
Number of controllable axes	Real drive axis	16 axes	32 axes	64 axes	128 axes	256 axes	8 axes	16 axes		
	Motion operation cycle [μs]	125, 250, 500, 1000, 1500, 2000, 2500, 3000, 3500, 4000, 4500, 5000, 5500, 6000, 6500, 7000, 7500, 8000					250, 500, 1000, 1500, 2000, 2500, 3000, 3500, 4000, 4500, 5000, 5500, 6000, 6500, 7000, 7500, 8000			
Servo amplifier connection		MR-J5-G, MR-J5W2-G, MR-J5W3-G, MR-J5D1-G4, MR-J5D2-G4, MR-J5D3-G4, TSN-compatible drive, MR-JET								
Absolute position control system		64 bit control/32 bit control								
Positioning range		64 bit floating-point (LREAL type)								
Interpolation function		Linear interpolation (4 axes maximum), 2-axis circular interpolation								
Control method		PTP control, speed control, speed-position switching control (future support), speed control/torque control/continuous operation to torque control, pressure control, multi-axis positioning data operation, position follow-up control, and motion cyclic instruction (position, velocity, and torque)					PTP control, speed control, speed-position switching control (future support), speed control/torque control/continuous operation to torque control, pressure control (future support), multi-axis positioning data operation, position follow-up control, and motion cyclic instruction (position, velocity, and torque)			
Operation cycles mixed		3 groups								
System memory size		256 MB					96 MB			
Size of built-in ROM for user data		30 MB (Data memory is used.)			60 MB (Data memory is used.)			15 MB (Data memory is used.)		
Axis		Real drive axis, virtual drive axis, real encoder axis, virtual encoder axis, and virtual linked axis								
	Axes group	0: Not set 1...: Setting axes group No.								
	Real drive axis	Servo amplifier								
	Real encoder axis	Via a servo amplifier								
Compensation function		Driver unit conversion function and phase compensation function (future support)					Driver unit conversion function and phase compensation function (future support)			
Synchronous control	Instruction	Advanced synchronous control and cam operation start (MC_CamIn)								
	Module	Master axis, cam, gear, and clutch								
	Master axis	Real drive axis, virtual drive axis, real encoder axis, virtual encoder axis, and virtual linked axis								
Start/stop		Start, stop, restart, buffer mode, and forced stop								
Home position return	Home position return method	Driver home position return method (use the home position return method set in the driver)								
	Positional control	Linear interpolation (2...4 axes) 2-axis circular interpolation								
Manual control		JOG operation								
Direct control	Speed control	Speed control not including position loop and speed control including position loop								
	Torque control	Torque control and continuous operation to torque control								
Absolute positioning system		Provided (batteryless)								
Function to limit control	Velocity limit	Velocity set range								
	Torque limit	Positive direction torque limit value, negative direction torque limit value								
	Forced stop	Enabled/disabled switching								
	Software stroke limit	Check the movable range at the set position and the machine feed value.								
Function to change control content	Hardware stroke limit	●								
	Set velocity change	●								
	Current value change	●								
	Acceleration/deceleration process change	Acceleration/deceleration and acceleration/deceleration time								
	Torque limit value change	●								
Function	Target position change	Target position change and movement distance change								
	Override	●								
	History data	Position data history								
	Axis emulation	●								
	Touch probe (mark detection)	●								
	Monitoring of servo data	Cyclic transmission and transient transmission								
	Servo system recorder	Future support					-			
Digital cam switch	●									
Operation profile data (cam) specifications										
Number of registrations		60000 maximum (settable number from engineering tool: 1024)								
Cam data	Type	Cam data and rotary knife								
	Interpolation method	Specifying for each section, linear interpolation, and spline interpolation								
	Profile ID	1...60000								
	Resolution	8...65535 (optional)								
	Unit of length per cycle setting	mm, inch, pulse, degree								
Unit of stroke amount	%, mm, inch, pulse, degree									
Cam auto-generation		Cam auto-generation cam for rotary knife								

Item	MXR300-16	MXR300-32	MXR300-64	MXR500-128	MXR500-256	MXF100-8-N32 MXF100-8-P32	MXF100-16-N32 MXF100-16-P32	
Network (CC-Link IE TSN) specifications								
Transmission speed	1 Gbps/100 Mbps							
Maximum number of connectable stations per network	254 stations (master station: 1, device station: 253 ^{*1}) ^{*2}					39 stations (master station: 1, device station: 38)	47 stations (master station: 1, device station: 46)	
Network topology	Line connection, star connection, coexistence of line and star connections							
Overall cable length	Line connection	25300 m (when 254 stations are connected)				3800 m (when 39 stations are connected)	4600 m (when 47 stations are connected)	
	Others	Depends on the system configuration.						
Maximum station-to-station distance	100 m							
Maximum number of link points per network	RX/RV	16K points (16384 points, 2 KB) for each						
	RWr/RWw	8K points (8192 points, 16 KB) for each						
	LB (future support)	32K points (32768 points, 4 KB)					-	
	LW (future support)	16K points (16384 points, 32 KB)					-	
Maximum number of link points per station	RX/RV	16K points (16384 points, 2 KB) for each				Master station: 8K points (8192 points, 1 KB) for each		
	RWr/RWw	8K points (8192 points, 16 KB) for each				Master station: 4K points (4096 points, 8 KB) for each		
Connection cable	Ethernet cable (Category 5e or higher)							
Communication method	Time sharing method							
Transient transmission capacity	Maximum 1920 bytes							

*1: The maximum number of connectable stations becomes 256 when modules that operate as extension modules, such as a multiple-axes drive unit, are included in the number.

*2: Device stations supporting connections to 253 stations will be available in the future. For details, refer to the Technical Bulletin (FA-A-0451).

Function list

●: Supported, -: Not supported

Item	MX-R model	MX-F model	
General	Data logging function	●	
	SLMP communication	●	
	Firmware update function	●	
	Event history function	●	
	Backup/restoration	●	
	Inter-module synchronization function	Future support	-
Engineering	Multiple interrupt	●	
Maintenance	Realtime monitor	●	
	Web server	●	
		Future support	
Network	File transfer function (FTP server)	●	
	File transfer function (FTP client)	●	
	Simple CPU communication	●	
	CC-Link IE Field Basic		Future support
	MQTT		Future support
Information linkage/ security	User authentication function	●	
	Encrypted communication function	●	
	OPC UA server function	●	
	OPC UA client function		Future support
	Recording function		Future support
	Network drive function		Future support
Built-in high-speed input/output	Pulse train positioning	-	
	High-speed counter	-	

MX-R model power supply module specifications

-: Not supported

Item	Power supply module					Redundant power supply module		
	R61P	R62P	R63P	R64P	R69P	R63RP	R64RP	R69RP
Input power supply voltage [V]	100...240 V AC (85...264 V AC)	100...240 V AC (85...264 V AC)	24 V DC (15.6...31.2 V DC)	100...240 V AC (85...264 V AC)	24 V DC (19.2...31.2 V DC)	24 V DC (19.2...31.2 V DC)	100...240 V AC (85...264 V AC)	24 V DC (19.2...31.2 V DC)
Input frequency	50/60 Hz ±5%	50/60 Hz ±5%	-	50/60 Hz ±5%	-	-	50/60 Hz ±5%	-
Maximum input apparent power [VA]	130	120	-	160	-	-	160	-
Maximum input power [W]	-	-	50	-	65	50	-	65
Rated output current (5 V DC) [A]	6.5	3.5	6.5	9	9	6.5	9	9
Rated output current (24 V DC) [A]	-	0.6	-	-	-	-	-	-

MX-F model power supply specifications

Item	Specifications
Rated voltage	24 V DC
Voltage fluctuation range	+20%, -15%
Allowable momentary power failure time	5 ms or less (at 24 V)
Power fuse	125 V, 3.15 A time-lag fuse
Inrush current	100 A, 0.06 ms or less 4.0 A, 350 ms or less
Power consumption	Controller alone: 13.6 W or less Maximum configuration for connection to the controller: 32.0 W or less (external 24 V DC power supply of extension devices is not included)
24 V DC built-in power supply capacity	500 mA
5 V DC built-in power supply capacity	720 mA

Product list

MELSEC MX Controller

Product name	Model	Overview
MX-R model	MXR300-16	Program memory: 100 MB, maximum number of controllable axes: 16 axes, built-in CC-Link IE TSN
	MXR300-32	Program memory: 100 MB, maximum number of controllable axes: 32 axes, built-in CC-Link IE TSN
	MXR300-64	Program memory: 100 MB, maximum number of controllable axes: 64 axes, built-in CC-Link IE TSN
	MXR500-128	Program memory: 150 MB, maximum number of controllable axes: 128 axes, built-in CC-Link IE TSN
MX-F model	MXR500-256	Program memory: 150 MB, maximum number of controllable axes: 256 axes, built-in CC-Link IE TSN
	MXF100-8-N32	Program memory: 30 MB, maximum number of controllable axes: 8 axes, built-in CC-Link IE TSN Input: 16 points, transistor (sink) output: 16 points
	MXF100-8-P32	Program memory: 30 MB, maximum number of controllable axes: 8 axes, built-in CC-Link IE TSN Input: 16 points, transistor (source) output: 16 points
	MXF100-16-N32	Program memory: 30 MB, maximum number of controllable axes: 16 axes, built-in CC-Link IE TSN Input: 16 points, transistor (sink) output: 16 points
	MXF100-16-P32	Program memory: 30 MB, maximum number of controllable axes: 16 axes, built-in CC-Link IE TSN Input: 16 points, transistor (source) output: 16 points

Common options

Product name	Model	Overview
SD memory card	NZ1MEM-2GBSD	SD memory card, 2 GB
	NZ1MEM-4GBSD	SDHC memory card, 4 GB
	NZ1MEM-8GBSD	SDHC memory card, 8 GB
	NZ1MEM-16GBSD	SDHC memory card, 16 GB
Battery	FX3U-32BL	Battery for long-time backup of the clock data

List of devices that support MX-R model

Product name	Model	Overview
Base unit		
Main base	R33B	3 slots, for MELSEC iQ-R Series module installation
	R35B	5 slots, for MELSEC iQ-R Series module installation
	R38B	8 slots, for MELSEC iQ-R Series module installation
	R312B	12 slots, for MELSEC iQ-R Series module installation
Extension base	R65B	5 slots, for MELSEC iQ-R Series module installation
	R68B	8 slots, for MELSEC iQ-R Series module installation
	R612B	12 slots, for MELSEC iQ-R Series module installation
Extended temperature range extension base	R610B-HT	10 slots, for MELSEC iQ-R Series module installation, operating ambient temperature: 0...60°C
Extension cable	RC06B	0.6 m cable, for extension base unit connection
	RC12B	1.2 m cable, for extension base unit connection
	RC30B	3 m cable, for extension base unit connection
	RC50B	5 m cable, for extension base unit connection
	RC100B	10 m cable, for extension base unit connection
Power supply module		
Power supply	R61P	AC power supply module, input: 100...240 V AC, output: 5 V DC/6.5 A
	R62P ¹	AC power supply module, input: 100...240 V AC, output: 5 V DC/3.5 A, 24 V DC/0.6 A
	R63P	DC power supply module, input: 24 V DC, output: 5 V DC/6.5 A
	R64P	AC power supply module, input: 100...240 V AC, output: 5 V DC/9 A
	R69P	DC power supply module, input: 24 V DC, output: 5 V DC/9 A
Redundant power supply	R63RP	DC power supply module, input: 24 V DC, output: 5 V DC/6.5 A, for redundant power supply system
	R64RP	AC power supply module, input: 100...240 V AC, output: 5 V DC/9 A, for redundant power supply system
	R69RP	DC power supply module, input: 24 V DC, output: 5 V DC/9 A, for redundant power supply system
I/O module		
AC input	RX10	16 points, 100...120 V AC (50/60 Hz), screw terminal block
	RX10-TS	16 points, 100...120 V AC (50/60 Hz), spring-clamp terminal block
	RX28	8 points, 100...240 V AC (50/60 Hz), screw terminal block
DC input	RX40C7	16 points, 24 V DC (input current: 7.0 mA), positive/negative common shared type, screw terminal block
	RX41C4	32 points, 24 V DC (input current: 4.0 mA), positive/negative common shared type, 40-pin connector
	RX42C4	64 points, 24 V DC (input current: 4.0 mA), positive/negative common shared type, 40-pin connector × 2
	RX40C7-TS	16 points, 24 V DC (input current: 7.0 mA), positive/negative common shared type, spring-clamp terminal block
	RX41C4-TS	32 points, 24 V DC (input current: 4.0 mA), positive/negative common shared type, spring-clamp terminal block
	RX70C4	16 points, 5 V DC (input current: 1.7 mA), 12 V DC (input current: 4.8 mA), positive/negative common shared type, screw terminal block
	RX71C4	32 points, 5 V DC (input current: 1.7 mA), 12 V DC (input current: 4.8 mA), positive/negative common shared type, 40-pin connector
DC high-speed input	RX40PC6H	16 points, 24 V DC (input current: 6.0 mA), minimum response time: 5 μs, positive common, screw terminal block
	RX40NC6H	16 points, 24 V DC (input current: 6.0 mA), minimum response time: 5 μs, negative common, screw terminal block
	RX41C6HS	32 points, 24 V DC (input current: 6.0 mA), minimum response time: 1 μs, positive/negative common shared type, 40-pin connector
	RX61C6HS	32 points, 5 V DC (input current: 6.0 mA), minimum response time: 1 μs, positive/negative common shared type, 40-pin connector
Input with diagnostic functions	RX40NC6B	16 points, 24 V DC (input current: 6.0 mA), negative common, screw terminal block
Contact output	RY10R2	16 points, 24 V DC 2 A/point, 240 V AC 2 A/point, screw terminal block
	RY10R2-TS	16 points, 24 V DC 2 A/point, 240 V AC 2 A/point, spring-clamp terminal block
	RY18R2A	8 points, 24 V DC 2 A/point, 240 V AC 2 A/point, screw terminal block
Triac output	RY20S6	16 points, 100...240 V AC, screw terminal block
Transistor output	RY40NT5P	Transistor (sink) output: 16 points, 12/24 V DC, screw terminal block
	RY41NT2P	Transistor (sink) output: 32 points, 12/24 V DC, 40-pin connector
	RY42NT2P	Transistor (sink) output: 64 points, 12/24 V DC, 40-pin connector × 2
	RY40PT5P	Transistor (source) output: 16 points, 12/24 V DC, screw terminal block
	RY41PT1P	Transistor (source) output: 32 points, 12/24 V DC, 40-pin connector
	RY42PT1P	Transistor (source) output: 64 points, 12/24 V DC, 40-pin connector × 2
	RY40NT5P-TS	Transistor (sink) output: 16 points, 12/24 V DC, spring-clamp terminal block
	RY41NT2P-TS	Transistor (sink) output: 32 points, 12/24 V DC, spring-clamp terminal block
	RY40PT5P-TS	Transistor (source) output: 16 points, 12/24 V DC, spring-clamp terminal block
	RY41PT1P-TS	Transistor (source) output: 32 points, 12/24 V DC, spring-clamp terminal block
Transistor high-speed output	RY41NT2H	Transistor (sink) output: 32 points, 5/12/24 V DC, minimum response time: 2 μs, 40-pin connector
	RY41PT2H	Transistor (source) output: 32 points, 5/12/24 V DC, minimum response time: 2 μs, 40-pin connector
Output with diagnostic functions	RY40PT5B	Transistor (source) output: 16 points, 24 V DC, screw terminal block
I/O combined	RH42C4NT2P	DC input: 32 points, 24 V DC (input current: 4.0 mA), positive/negative common shared type, transistor (sink) output: 32 points, 12/24 V DC, 40-pin connector × 2

*1: MXR500-□: Can be used only on the extension base unit.
MXR300-□: Can be used on the R33B, R35B, and extension base unit.

Product name	Model	Overview
Analog module		
Analog-digital conversion	R60AD4	Voltage/current input: 4 channels, -10...10 V DC/-32000...32000, 0...20 mA DC/0...32000, 80 µs/channel, screw terminal block
	R60AD18	Current input: 8 channels, 0...20 mA DC/0...32000, 80 µs/channel, screw terminal block
	R60ADV8	Voltage input: 8 channels, -10...10 V DC/-32000...32000, 80 µs/channel, screw terminal block
High-speed analog-digital conversion	R60ADPH4	Voltage/current input: 4 channels, -10...10 V DC/-32000...32000, 0...20 mA DC/0...32000, 1 µs/channel, screw terminal block
Channel isolated analog-digital conversion	R60AD8-G	Voltage/current input: 8 channels, channel isolated, -10...10 V DC/-32000...32000, 0...20 mA DC/0...32000, 10 ms/channel, 40-pin connector
	R60AD16-G	Voltage/current input: 16 channels, channel isolated, -10...10 V DC/-32000...32000, 0...20 mA DC/0...32000, 10 ms/channel, 40-pin connector × 2
Channel isolated analog input module	R60AD6-DG	Current input: 6 channels, channel isolated, 4...20 mA DC (when connected to a 2-wire transmitter)/0...32000, 0...20 mA DC/0...32000, 10 ms/channel, 40-pin connector
Digital-analog conversion	R60DA4	Voltage/current output: 4 channels, -32000...32000/-10...10 V DC, 0...32000/0...20 mA DC, 80 µs/channel, screw terminal block
	R60DA18	Current output: 8 channels, 0...32000/0...20 mA DC, 80 µs/channel, screw terminal block
	R60DAV8	Voltage output: 8 channels, -32000...32000/-10...10 V DC, 80 µs/channel, screw terminal block
High-speed digital-analog conversion	R60DAH4	Voltage/current output: 4 channels, -32000...32000/-10...10 V DC, 0...32000/0...20 mA DC, 1 µs/channel, screw terminal block
Channel isolated digital-analog conversion	R60DA8-G	Voltage/current output: 8 channels, channel isolated, -32000...32000/-12...12 V DC, 0...32000/0...20 mA DC, 1 ms/channel, 40-pin connector
	R60DA16-G	Voltage/current output: 16 channels, channel isolated, -32000...32000/-12...12 V DC, 0...32000/0...20 mA DC, 1 ms/channel, 40-pin connector × 2
Temperature input module, temperature control module		
Channel isolated thermocouple input	R60TD8-G	Thermocouple (B, R, S, K, E, J, T, and N), input: 8 channels, channel isolated, 30 ms/channel, 40-pin connector
Channel isolated RTD input	R60RD8-G	RTD (Pt100, JPt100, Ni100, and Pt50), input: 8 channels, channel isolated, 10 ms/channel, 40-pin connector
Temperature control	R60TCTRT2TT2	Thermocouple (B, R, S, K, E, J, T, N, U, L, PLII, and W5Re/W26Re), input: 4 channels (RTD input can also be used for 2 channels), screw terminal block
	R60TCTRT2TT2BW	Thermocouple (B, R, S, K, E, J, T, N, U, L, PLII, and W5Re/W26Re), input: 4 channels (RTD input can also be used for 2 channels), heater disconnection detection, screw terminal block
	R60TCRT4	RTD (Pt100 and JPt100), input: 4 channels, screw terminal block
	R60TCRT4BW	RTD (Pt100 and JPt100), input: 4 channels, heater disconnection detection, screw terminal block
	R60TCTRT2TT2-TS	Thermocouple (B, R, S, K, E, J, T, N, U, L, PLII, and W5Re/W26Re), input: 4 channels (RTD input can also be used for 2 channels), spring-clamp terminal block
	R60TCRT4-TS	RTD (Pt100 and JPt100), input: 4 channels, spring-clamp terminal block
High-speed counter, isolated pulse input, flexible high-speed I/O control module		
High-speed counter	RD62P2	5/12/24 V DC input: 2 channels, maximum counting speed: 200k pulse/s, external output: transistor (sink) output
	RD62D2	Differential input: 2 channels, maximum counting speed: 8M pulse/s, external output: transistor (sink) output
	RD62P2E	5/12/24 V DC input: 2 channels, maximum counting speed: 200k pulse/s, external output: transistor (sink) output
Channel isolated pulse input	RD60P8-G	5/12...24 V DC input: 8 channels, channel isolated, maximum counting speed: 30k pulse/s
Flexible high-speed I/O control	RD40PD01	Input: 12 points (5 V DC/24 V DC/differential common), maximum counting speed: 8M pulse/s (differential), output: 14 points (5...24 V DC: 8 points, differential: 6 points), maximum output pulse: 8M pulse/s (differential)
Positioning module		
Positioning	RD75P2	Open collector output: 2 axes, maximum output pulse: 200k pulse/s, linear interpolation, circular interpolation
	RD75P4	Open collector output: 4 axes, maximum output pulse: 200k pulse/s, linear interpolation, circular interpolation, helical interpolation
	RD75D2	Differential driver output: 2 axes, maximum output pulse: 5M pulse/s, linear interpolation, circular interpolation
	RD75D4	Differential driver output: 4 axes, maximum output pulse: 5M pulse/s, linear interpolation, circular interpolation, helical interpolation
Information module		
Ethernet interface with built-in CC-Link IE	RJ71EN71	1 Gbps/100 Mbps/10 Mbps: 2 ports Multiple networks compatible (Ethernet/CC-Link IE Field Network, CC-Link IE Controller Network (twisted pair cable))
Serial communication	RJ71C24	230.4 Kbps maximum, RS-232: 1 channel, RS-422/485: 1 channel
	RJ71C24-R2	230.4 Kbps maximum, RS-232: 2 channels
	RJ71C24-R4	230.4 Kbps maximum, RS-422/485: 2 channels
MES interface	RD81MES96N	Linked with database*1
GP-IB interface	RJ71GB91	GP-IB system compatible controller/device
Network module		
CC-Link IE TSN	RJ71GN11-T2	1 Gbps/100 Mbps, master station/local station
	RJ71GN11-SX	1 Gbps, optical fiber cable, master station/local station
	RJ71GN11-EIP	1 Gbps/100 Mbps, master station/local station, EtherNet/IP™ compatible
CC-Link IE Controller Network	RJ71GP21-SX	1 Gbps, optical fiber cable, control station/normal station, standard type
	RJ71GP21S-SX	1 Gbps, optical fiber cable, control station/normal station, with external power supply function
CC-Link IE Field Network	RJ71GF11-T2	1 Gbps, master station/local station
CC-Link system master/local	RJ61BT11	10 Mbps maximum, master station/local station, CC-Link Ver.2 compatible
AnyWireASLINK master	RJ51AW12AL	AnyWireASLINK system compatible, master station
CANopen®	RJ71CN91	CANopen® system compatible, NMT master/NMT slave
DeviceNet master/slave	RJ71DN91	DeviceNet® system compatible, master/slave
BACnet®	RJ71BAC96	BACnet® system compatible, controller/workstation
Energy measuring module		
Energy measuring	RE81WH	Energy measuring: 1 circuit, data refreshing cycle: 10 to 10000 ms (can be set in increments of 10 ms) ²
Blank cover module		
Blank cover	RG60	Blank cover for main base unit and extension base unit I/O slot

*1: The MX MESInterface-R (SW1DND-RMESIF) is required additionally.

*2: A dedicated split-type current sensor is required additionally.

■ List of devices that support MX-F model

Product name	Model	Overview
I/O module for MX-F model	MXF100-X32	Input module, input: 32 points, sink/source shared type, spring-clamp terminal block
	MXF100-Y16R	Output module, output: 16 points, relay output, spring-clamp terminal block
	MXF100-Y32N	Output module, output: 32 points, transistor (sink) output, spring-clamp terminal block
	MXF100-Y32P	Output module, output: 32 points, transistor (source) output, spring-clamp terminal block
	MXF100-H32N	I/O module, input: 16 points, sink/source shared type, output: 16 points, transistor (sink) output, spring-clamp terminal block
MXF100-H32P	I/O module, input: 16 points, sink/source shared type, output: 16 points, transistor (source) output, spring-clamp terminal block	
I/O module ^{*1}		
Input	FX5-8EX/ES	Input module, input: 8 points, sink/source shared type, screw terminal block
	FX5-16EX/ES	Input module, input: 16 points, sink/source shared type, screw terminal block
Output	FX5-8EYR/ES	Output module, output: 8 points, relay output, screw terminal block
	FX5-16EYR/ES	Output module, output: 16 points, relay output, screw terminal block
	FX5-8EYT/ES	Output module, output: 8 points, transistor (sink) output, screw terminal block
	FX5-16EYT/ES	Output module, output: 16 points, transistor (sink) output, screw terminal block
	FX5-8EYT/ESS	Output module, output: 8 points, transistor (source) output, screw terminal block
Input/output	FX5-16EYT/ESS	Output module, output: 16 points, transistor (source) output, screw terminal block
	FX5-16ET/ES	I/O module, input: 8 points, sink/source shared type, output: 8 points, transistor (sink) output, screw terminal block
	FX5-16ET/ESS	I/O module, input: 8 points, sink/source shared type, output: 8 points, transistor (source) output, screw terminal block
Powered I/O	FX5-32ER/DS	Rated voltage 24 V DC, I/O module, input: 16 points, sink/source shared type, output: 16 points, relay output, screw terminal block
	FX5-32ET/DS	Rated voltage 24 V DC, I/O module, input: 16 points, sink/source shared type, output: 16 points, transistor (sink) output, screw terminal block
	FX5-32ET/DSS	Rated voltage 24 V DC, I/O module, input: 16 points, sink/source shared type, output: 16 points, transistor (source) output, screw terminal block
High-speed pulse input/output	FX5-16ET/ES-H	High-speed counter: 2 channels, pulse train: 2 axes, input: 8 points, sink/source shared type, output: 8 points, transistor (sink) output, screw terminal block
	FX5-16ET/ESS-H	High-speed counter: 2 channels, pulse train: 2 axes, input: 8 points, sink/source shared type, output: 8 points, transistor (source) output, screw terminal block
Extension power supply unit		
Extension power supply	FX5-C1PS-5V	Power supply for extension
Intelligent function module ^{*1}		
High-speed counter	FX5-2HC/ES	High-speed counter: 2 channels, input type: differential line driver, spring-clamp terminal block type
Analog input	FX5-4AD	Analog input: 4 channels, spring-clamp terminal block type
Analog output	FX5-4DA	Analog output: 4 channels, spring-clamp terminal block type
Multiple input	FX5-8AD	Multiple inputs (voltage, current, thermocouple, and RTD): 8 channels, spring-clamp terminal block type
Temperature control	FX5-4LC	Input (thermocouple, RTD, and low voltage input): 4 points, input (current detector): 4 points
		Output (open collector transistor output): 4 points, spring-clamp terminal block type
Ethernet	FX5-ENET	Ethernet module, CC-Link IE Field Network Basic
	FX5-ENET/IP	Ethernet module, EtherNet/IP™ system compatible, scanner, EtherNet/IP communication function: Class 1 instance communications, Class3 message communications, UCMM message communications
EtherNet/IP™	FX5-EIP	EtherNet/IP™ system compatible, scanner, EtherNet/IP communication function: Class1 instance communications, Class1 tag communications, Class3 message communications, Class3 tag communications, UCMM message communications, UCMM tag communications
CC-Link IE TSN master/local	FX5-CCLGN-MS	CC-Link IE TSN master/local module
CC-Link system master/intelligent device	FX5-CCL-MS	Master station for CC-Link, intelligent device station for CC-Link
Connector conversion module		
Connector conversion	FX5-CNV-IFC	Connector conversion module to connect an extension device from FX5 (extension connector type) to FX5 (extension cable type)
Extension cable		
Extension cable	FX5-30EC	Extension cable for extension module (0.3 m)
	FX5-65EC	Extension cable for extension module (0.65 m)
Conversion adapter		
Connector conversion	FX5-CNV-BC	Conversion adapter
Expansion adapter		
Analog I/O	FX5-4A-ADP	Analog input: 2 channels, analog output: 2 channels European-type terminal block type
Analog input	FX5-4AD-ADP	Analog input: 4 channels European-type terminal block type
Analog output	FX5-4DA-ADP	Analog output: 4 channels European-type terminal block type
RTD temperature sensor input	FX5-4AD-PT-ADP	RTD temperature sensor input: 4 channels European-type terminal block type
Thermocouple temperature sensor input	FX5-4AD-TC-ADP	Thermocouple temperature sensor input: 4 channels European-type terminal block type
RS-232 communication	FX5-232ADP	RS-232C communication D-sub 9-pin type
RS-485 communication	FX5-485ADP	RS-485 communication European-type terminal block type

*1: When using the extension cable type module, the FX5-CNV-IFC or FX5-C1PS-5V is required.

■ List of CC-Link IE TSN connection devices

Product name	Model	Overview
Block type remote module		
Input	NZ2GN2S1-16D	16 points, 24 V DC, input response time: 0...70 ms, positive/negative common shared type, spring-clamp terminal block, 1-wire type
	NZ2GN2S1-32D	32 points, 24 V DC, input response time: 0...70 ms, positive/negative common shared type, spring-clamp terminal block, 1-wire type
	NZ2GN2B1-16D	16 points, 24 V DC, input response time: 0...70 ms, positive/negative common shared type, screw terminal block, 1-wire type
	NZ2GN2B1-32D	32 points, 24 V DC, input response time: 0...70 ms, positive/negative common shared type, screw terminal block, 1-wire type
	NZ2GNCE3-32D	32 points, 24 V DC, input response time: 0...70 ms, positive common, sensor connector (e-CON), 3-wire type
	NZ2GNCF1-32D	32 points, 24 V DC, input response time: 0...70 ms, positive/negative common shared type, 40-pin connector, 1-wire type
Output	NZ2GN2S1-16T	16 points, 12/24 V DC, sink, spring-clamp terminal block, 1-wire type
	NZ2GN2S1-16TE	16 points, 12/24 V DC, source, spring-clamp terminal block, 1-wire type
	NZ2GN2S1-32T	32 points, 12/24 V DC, sink, spring-clamp terminal block, 1-wire type
	NZ2GN2S1-32TE	32 points, 12/24 V DC, source, spring-clamp terminal block, 1-wire type
	NZ2GN2B1-16T	16 points, 12/24 V DC, sink, screw terminal block, 1-wire type
	NZ2GN2B1-16TE	16 points, 12/24 V DC, source, screw terminal block, 1-wire type
	NZ2GN2B1-32T	32 points, 12/24 V DC, sink, screw terminal block, 1-wire type
	NZ2GN2B1-32TE	32 points, 12/24 V DC, source, screw terminal block, 1-wire type
I/O combined	NZ2GN2S1-32DT	Input: 16 points, 24 V DC, input response time: 0...70 ms, positive common Output: 16 points, 24 V DC, sink, spring-clamp terminal block, 1-wire type
	NZ2GN2S1-32DTE	Input: 16 points, 24 V DC, input response time: 0...70 ms, negative common Output: 16 points, 24 V DC, source, spring-clamp terminal block, 1-wire type
	NZ2GN2B1-32DT	Input: 16 points, 24 V DC, input response time: 0...70 ms, positive common Output: 16 points, 24 V DC, sink, screw terminal block, 1-wire type
	NZ2GN2B1-32DTE	Input: 16 points, 24 V DC, input response time: 0...70 ms, negative common Output: 16 points, 24 V DC, source, screw terminal block, 1-wire type
	NZ2GNCE3-32DT	Input: 16 points, 24 V DC, input response time: 0...70 ms, positive common Output: 16 points, 24 V DC, sink, sensor connector (e-CON), 3-wire type
Analog input	NZ2GN2S-60AD4	4 channels, input: -10...10 V DC, 0...20 mA DC Conversion speed: 200 µs/channel, spring-clamp terminal block
	NZ2GN2B-60AD4	4 channels, input: -10...10 V DC, 0...20 mA DC Conversion speed: 200 µs/channel, screw terminal block
Analog output	NZ2GN2B-60DA4	4 channels, output: -10...10 V DC, 0...20 mA DC Conversion speed: 200 µs/channel, spring-clamp terminal block
	NZ2GN2S-60DA4	4 channels, output: -10...10 V DC, 0...20 mA DC Conversion speed: 200 µs/channel, screw terminal block
Waterproof/dustproof type (IP67) remote module		
Input	NZ2GN12A4-16D	16 points, 24 V DC, input response time: 0...70 ms, positive common, waterproof connector, 2...4-wire type
	NZ2GN12A4-16DE	16 points, 24 V DC, input response time: 0...70 ms, negative common, waterproof connector, 2...4-wire type
Output	NZ2GN12A2-16T	16 points, 12/24 V DC, transistor, sink, waterproof connector, 2-wire type
	NZ2GN12A2-16TE	16 points, 12/24 V DC, transistor, source, waterproof connector, 2-wire type
I/O combined	NZ2GN12A42-16DT	Input: 8 points, 24 V DC, input response time: 0...70 ms, positive common, 2...4-wire type Output: 8 points, 12/24 V DC, sink, 2-wire type, waterproof connector
	NZ2GN12A42-16DTE	Input: 8 points, 24 V DC, input response time: 0...70 ms, negative common, 2...4-wire type Output: 8 points, 12/24 V DC, source, 2-wire type, waterproof connector
Industrial switching hub		
Industrial switching hub	NZ2MHG-TSNT4	Industrial switching hub
	NZ2MHG-TSNT8F2	

Software MELSOFT - Engineering software

Product name	Overview
MELSOFT iQ Works	FA engineering software ^{*1} · System management software "MELSOFT Navigator" · Programmable controller engineering software "MELSOFT GX Works3" ^{*2} (including GX Works2, PX Developer ^{*3}) · Motion controller engineering software "MELSOFT MT Works2" · HMI/GOT screen design software "MELSOFT GT Works3" · Robot programming software "MELSOFT RT ToolBox3" ^{*4} · Inverter setup software "MELSOFT FR Configurator2" · Servo amplifier setup software "MELSOFT MR Configurator2" · C Controller module setting and monitoring tool "MELSOFT CW Configurator"
MELSOFT GX Works3 ^{*2}	· Programmable controller engineering software (including GX Works2, PX Developer ^{*3})

*1: For details on the supported models of each software, refer to the manual for the product used.

*2: MELSOFT GX Works3 can be switched between Japanese, English, and Chinese (Simplified).

*3: The programming tool and monitoring tool for process control are included.

*4: RT ToolBox3 mini (simplified version) will be installed when iQ Works product ID is used. When RT ToolBox3 (with simulation function) is required, please purchase RT ToolBox3 product ID.

MELSOFT iQ Works

Product name	Model	Overview
MELSOFT iQ Works	SW2DND-IQWK-EC	Site license

MELSOFT GX Works3

Product name	Model	Overview
MELSOFT GX Works3	SW1DND-GXW3-EC	Site license

MELSOFT GX LogViewer

Product name	Model	Overview
MELSOFT GX LogViewer	SW1DNN-VIEWER-M	A tool for displaying and analyzing large-capacity data collected by the data logging function of the logger module and controller

CPU Module Logging Configuration Tool

Product name	Model	Overview
CPU Module Logging Configuration Tool	SW1DNN-LLUTL-M	A tool for configuring the logging settings of the controller in a wizard form

MELSOFT GX VideoViewer Future support ^{*1*2}

Product name	Model	Overview
MELSOFT GX VideoViewer	SW1DNN-REPROA-M	A tool for displaying and analyzing the saved videos using a camera recorder module

*1: The MX-F model is not supported.

*2: The cooperation of MX-R model will be supported in the future.

MELSOFT GX VideoViewer Pro Future support ^{*1*2}

Product name	Model	Overview
MELSOFT GX VideoViewer Pro	SW1DND-REPROAA-M	Standard license A tool with an AI analysis function based on Mitsubishi Electric's proprietary AI technology added to GX VideoViewer

*1: The MX-F model is not supported.

*2: The cooperation of MX-R model will be supported in the future.

MELSOFT Mirror Future support ^{*1}

Product name	Model	Overview
MELSOFT Mirror Perpetual license	SW1DND-LCS-MA1	Perpetual, 10 modules
	SW1DND-LCS-MA2	Perpetual, 20 modules
	SW1DND-LCS-MA5	Perpetual, 50 modules
	SW1DND-LCS-MZ	Perpetual, additional 10 modules
MELSOFT Mirror One year license	SW1DND-LCS-MA1Q12	Subscription, 10 modules
	SW1DND-LCS-MA2Q12	Subscription, 20 modules
	SW1DND-LCS-MA5Q12	Subscription, 50 modules
	SW1DND-LCS-MZQ12	Subscription, additional 10 modules

*1: The cooperation of MX-R model and MX-F model will be supported in the future.

MELSOFT MaiLab Future support ^{*1}

Product name	Model	Overview
MELSOFT MaiLab Basic license	SW1DND-MAILAB-MQ12	Subscription (year)/New
	SW1DND-MAILABRE-MQ12	Subscription (year)/Update
MELSOFT MaiLab Additional user license	SW1DND-MAILABAN-MQ12	Subscription (year)
MELSOFT MaiLab Additional diagnostics license	SW1DND-MAILABPR-M	Perpetual, 1 license
	SW1DND-MAILABPR-MA5	Perpetual, 5 licenses
	SW1DND-MAILABPR-MA10	Perpetual, 10 licenses

*1: The cooperation of MX-R model and MX-F model will be supported in the future.

MELSOFT Gemini Future support *1

Product name	Model	Overview
MELSOFT Gemini Essential Standalone	SW1DND-3DSIME-MQ12	Outright purchase, 1 year maintenance included
	SW1DND-3DSET-MQ06	Subscription (6 months)
	SW1DND-3DSET-MQ12	Subscription (12 months)
MELSOFT Gemini Essential Network	SW1DND-3DSEK-MQ12	Outright purchase, 1 year maintenance included
	SW1DND-3DSEKT-MQ06	Subscription (6 months)
	SW1DND-3DSEKT-MQ12	Subscription (12 months)
MELSOFT Gemini Professional Standalone	SW1DND-3DSIMR-MQ12	Outright purchase, 1 year maintenance included
	SW1DND-3DSRT-MQ06	Subscription (6 months)
	SW1DND-3DSRT-MQ12	Subscription (12 months)
MELSOFT Gemini Professional Network	SW1DND-3DSRK-MQ12	Outright purchase, 1 year maintenance included
	SW1DND-3DSRKT-MQ06	Subscription (6 months)
	SW1DND-3DSRKT-MQ12	Subscription (12 months)
MELSOFT Gemini Premium Standalone	SW1DND-3DSIMM-MQ12	Outright purchase, 1 year maintenance included
	SW1DND-3DSMT-MQ06	Subscription (6 months)
	SW1DND-3DSMT-MQ12	Subscription (12 months)
MELSOFT Gemini Premium Network	SW1DND-3DSMK-MQ12	Outright purchase, 1 year maintenance included
	SW1DND-3DSMKT-MQ06	Subscription (6 months)
	SW1DND-3DSMKT-MQ12	Subscription (12 months)

*1: The cooperation of MX-R model and MX-F model will be supported in the future.

GENESIS64™ Future support *1

Product name	Model	Overview
GENESIS64™	GEN64-BASIC-□	A license to develop/operate the GENESIS64™ Basic SCADA system. The □ in the product model indicates the number of tags (75...5000).
	GEN64-BASIC-JPN□	A bundled product that combines the basic functions of GENESIS64™ Basic SCADA. The □ in the product model indicates the number of tags (5000...30000).
	GEN64-APP-□	A license to develop/operate the GENESIS64™ Advanced system. The □ in the product model indicates the number of tags (75...250000).
	WEBHMI-□	A license to monitor and control the GENESIS64™ server from the client terminal. Monitoring and control via the web and mobile are supported.
	MOBILEHMI-□	A license to monitor and control the GENESIS64™ server from the client terminal. Monitoring and control via mobile are supported.
	GEN64-HH-□	An optional item to collect data at high speed and with large capacity

*1: The cooperation of MX-R model and MX-F model will be supported in the future.

BACnet is a trademark of ASHRAE.
CiA and CANopen are registered EU trademarks of CiA e. V.
EtherNet/IP, DeviceNet, and CIP Safety are trademarks of ODVA, Inc.
Analytix is a registered trademark of Mitsubishi Electric Iconics Digital Solutions, Inc. and GENESIS64, GENESIS32, Hyper Historian, IoTWorX, KPIWorX, CFSWorX, MobileHMI, WebHMI, GENESIS, Hyper Historian, and Data Historian are trademarks of Mitsubishi Electric Iconics Digital Solutions, Inc.
MATLAB, Simulink, and PLC Coder are registered trademarks of The MathWorks, Inc.
Microsoft, Access, ActiveX, Azure, Bing, Microsoft Edge, Excel, HoloLens, Internet Explorer, SQL Server, Silverlight, Surface, Visual Basic, Visual C#, Visual C++, Visual Studio, Windows, Windows Phone, and Windows Server, Windows Vista are trademarks of the Microsoft group of companies.
OPC UA logo and OPC CERTIFIED logo are registered trademarks of OPC Foundation.
The name PLCopen® is a registered trademark owned by the association PLCopen.
QR Code is a trademark or a registered trademark of DENSO WAVE INCORPORATED in JAPAN, the United States and/or other countries.
All other company names and product names mentioned herein are trademarks or registered trademarks of their respective owners.
Trademark symbols such as “™” and “®” might be omitted in this document.

Precautions before use

This publication explains the typical features and functions of the products herein and does not provide restrictions or other information related to usage and module combinations. Before using the products, always read the product user manuals. Mitsubishi Electric will not be held liable for damage caused by factors found not to be the cause of Mitsubishi Electric; opportunity loss or lost profits caused by faults in Mitsubishi Electric products; damage, secondary damage, or accident compensation, whether foreseeable or not, caused by special factors; damage to products other than Mitsubishi Electric products; or any other duties.

For safe use

- To use the products given in this publication properly, always read the relevant manuals before beginning operation.
- The products have been manufactured as general-purpose parts for general industries, and are not designed or manufactured to be incorporated in a device or system used in purposes related to human life.
- Before using the products for special purposes such as nuclear power, electric power, aerospace, medicine or passenger-carrying vehicles, consult with Mitsubishi Electric.
- The products have been manufactured under strict quality control. However, when installing the products where major accidents or losses could occur if the products fail, install appropriate backup or fail-safe functions in the system.

Discover the latest information in Factory Automation

Factory Automation Global website

Mitsubishi Electric Factory Automation provides a mix of services to support its customers worldwide. A consolidated global website is the main portal, offering a selection of support tools and a window to its local Mitsubishi Electric sales and support network.

From here you can find:

- Overview of available factory automation products
- Library of downloadable literature
- Support tools such as online e-learning courses, terminology dictionary, etc.
- Global sales and service network portal
- Latest news related to Mitsubishi Electric factory automation

Mitsubishi Electric Factory Automation Global website:
www.MitsubishiElectric.com/fa

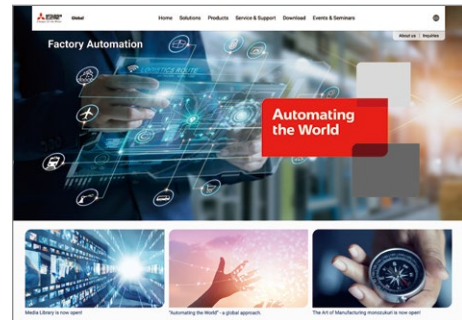

Mitsubishi Electric FA e-Learning

An extensive library of e-learning courses covering the factory automation product range.

Courses from beginner to advanced levels of difficulty are available anytime anywhere.



Beginner level

Designed for newcomers to Mitsubishi Electric Factory Automation products gaining a background of the fundamentals and an overview of various products related to the course.

Basic to Advanced levels

Various different features are explained along with setup, programming, and network configuration.

Innovative next-generation e-Manual

A next-generation digital manual that consolidates factory automation products manuals into an easy-to-use package with various useful features.

e-Manual Viewer

Multiple manuals can be cross-searched at once. Multiple users can share the latest manuals and knowhow with document sharing function.



e-Manual Create

Software for converting word files and chm files to e-Manual documents. User's customized machine manuals can be converted to e-Manual documents, allowing consolidated management of user's maintenance information and Mitsubishi Electric product information.

Find information on products, factory automation, e-F@ctory solutions and other topics

Follow us on Social Media

YouTube



Mitsubishi Electric FA Global

LinkedIn



Mitsubishi Electric FA Global

X



Mitsubishi Electric FA Global
@Mitsubishi_FA

Creating Solutions Together.



Industrial Computer



Controllers



Computerized Numerical Controllers



Drive Products



Human Machine Interfaces



Robots



Low-voltage Power Distribution Products



Medium-voltage Power Distribution Products



Energy Saving Supporting Devices



Processing Machines: EDM, Lasers



Engineering and Solution Software

Mitsubishi Electric's FA division provides robust support for our customers' manufacturing needs. We offer a vast array of FA products, including industry-leading PLCs, control devices, drive devices, energy efficiency support equipment, power distribution control equipment, and industrial mechatronics. Our presence on every type of production floor enables us to assist in labor-saving initiatives and quality improvements, helping customers achieve sustainable manufacturing. We also address challenges such as decarbonization and labor shortages through the utilization of automation technology.

Additionally, by leveraging synergies among FA technologies, manufacturing expertise, and digital innovations, we aim to streamline the construction of systems for data collection, accumulation, and analysis. This contributes to reducing manufacturing and quality losses.

We enable flexible manufacturing processes that respect legacy systems while embracing innovations to drive optimization. As your solution partner, Mitsubishi Electric FA delivers high-performance, high-quality products that enhance your competitiveness.

Let's automate the world together!

Sales office

MITSUBISHI ELECTRIC Factory Automation Global Website

► Locations Worldwide

www.MitsubishiElectric.com/fa/about-us/overseas/



e-F@ctory

Mitsubishi Electric's e-F@ctory concept utilizes both FA and IT technologies, to reduce the total cost of development, production and maintenance, with the aim of achieving manufacturing that is a "step ahead of the times". It is supported by the e-F@ctory Alliance Partners covering software, devices, and system integration, creating the optimal e-F@ctory architecture to meet the end users needs and investment plans.

**e-Factory
Alliance**

MITSUBISHI ELECTRIC CORPORATION
HEAD OFFICE: TOKYO BLDG., 2-7-3, MARUNOUCHI, CHIYODA-KU, TOKYO 100-8310, JAPAN